

2002

Development Progress
BATAM
INDONESIA



2001

2000

1999

1998

1997

1996

1995

1994

1993

1992



**REPUBLIC OF INDONESIA
BATAM INDUSTRIAL DEVELOPMENT AUTHORITY**

Development Progress 2002

BATAM

INDONESIA

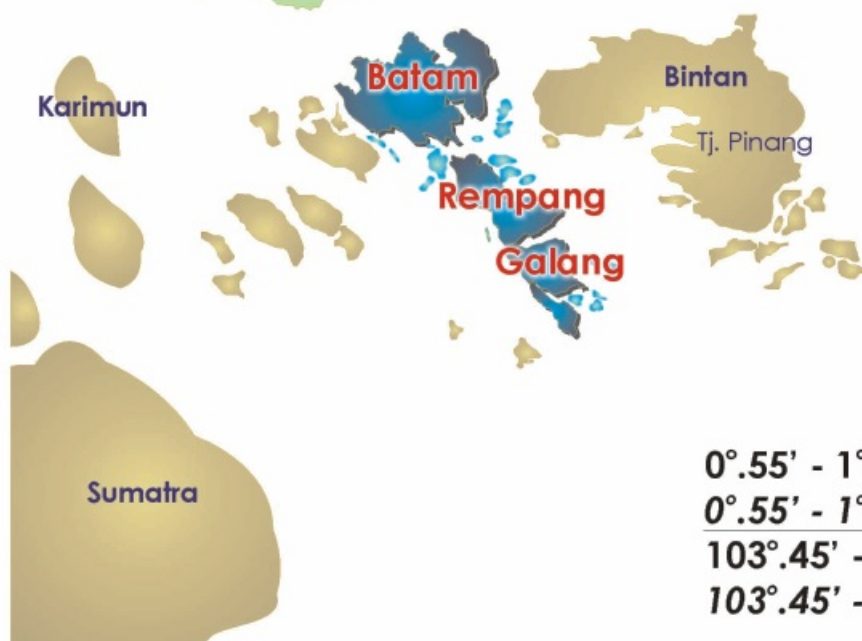

Table of Contents / Daftar Isi

	Page / Halaman
01. Orientation Map / Peta Orientasi	02
02. Master Plan of Batam - Rempang - Galang / Master Plan Batam - Rempang - Galang (Barelang)	03
03. Geographic Data / Data Geografis	04
04. Legal Platform of the Batam Industrial Development Authority / Landasan Hukum Otorita Batam	05
05. Development Periods of Batam / Periode Pembangunan Daerah Industri Pulau Batam	06
06. Batam Industrial Development Authority Organizational Chart / Struktur Organisasi Otorita Pengembangan Daerah Industri Pulau Batam	06
07. Population / Penduduk	07
08. Population Growth / Pertumbuhan Penduduk	07
09. Total Work Force Based on Business Sectors / Jumlah Tenaga Kerja Menurut Sektor Lapangan Usaha	08
10. Work Force Growth / Perkembangan Tenaga Kerja	08
11. Roads / Jalan Raya	09
12. Bridges / Jembatan	09
13. Sea Port Facilities / Pelabuhan Laut	10
14. Ship Calls / Kunjungan Kapal Laut	10
15. Batam Hang Nadim International Airport / Bandara Internasional Hang Nadim Batam	11
16. Aircraft Movement / Pergerakan Pesawat Udara	11
17. Electricity / Listrik	12
18. Water Supply / Air Bersih	13
19. Telecommunication / Telekomunikasi	14
20. Infrastructure of Information Technology / Infrastruktur Teknologi Informasi	15
21. Batam Intelligent Island / Batam Intelligent Island	15
22. Total Investment / Total Investasi	16
23. Comparison of Private Investment / Perbandingan Investasi Swasta	16
24. Government Investment / Investasi Pemerintah	17
25. Domestic Private Investment / Investasi Swasta Domestik	17
26. Foreign Private Investment / Investasi Swasta Asing	18
27. Comparison Private Investment by Type of Business / Investasi Swasta Menurut Jenis Kegiatan	18
28. Private Investment (Domestic & Foreign) / Total Investasi Swasta (Domestik & Asing)	18
29. Export from Batam / Ekspor dari Batam	19
30. Foreign Exchange Revenue / Pemasukan Devisa	19
31. Non Oil & Gas Export Value Comparison of Batam and Riau Province / Perbandingan Nilai Ekspor Non Migas Batam Terhadap Propinsi Riau	20
32. Tax Revenue from Batam / Penerimaan Pajak dari Batam	21
33. City of Batam Revenue / Penerimaan Kota Batam	21
34. Batam Economic Structure by Year / Struktur Ekonomi Batam per Tahun	22
35. Batam Economic Structure 2002 / Struktur Ekonomi Batam Tahun 2002	22
36. GDRP of Indonesia and Batam (Non Oil & Gas) 2002 / PDB Perkapita Indonesia dengan PDRB Perkapita dan Batam (Non Migas) tahun 2002	23
37. Foreign Visitors to Indonesia by Port of Arrival / Kunjungan Wisatawan Mancanegara ke Indonesia Menurut Pintu Masuk	23
38. Foreign Visitors to Batam / Wisatawan Mancanegara ke Batam	24
39. Foreign Visitor Spending in Batam / Penerimaan Devisa dari Wisatawan Mancanegara di Batam	24
40. Public Facilities / Fasilitas Umum	25
41. Social Facilities / Fasilitas Sosial	26
42. Joint Ventures between Indonesia and Foreign Countries / Investasi PMA Joint Venture Dengan Indonesia	27
43. Foreign Joint Ventures between Foreign Countries (including & not including Indonesia) / Tabel Investasi PMA Joint Venture (Dengan dan Tidak Dengan Indonesia)	27
44. Value of Foreign Direct Investments by Country / Tabel Nilai Investasi PMA Berdasarkan Asal Negara	28
45. Number of Foreign Direct Investments by Country / Tabel Investasi PMA Berdasarkan Asal Negara	28
46. Indicators of Batam Economic Growth 1993 to December 2002 / Indikator Pertumbuhan Batam Tahun 1993 s/d Desember 2002	29
47. Land Lease (per m ²) in Batam / Tarif Tanah per m ² di Batam	30
48. List of Hotels, Golf Courses and Marinas / Daftar Hotel, Lapangan Golf dan Marina	31

Orientation Map

Peta Orientasi



0°.55' - 1°.55' of North Latitude

0°.55' - 1°.55' Lintang Utara

103°.45' - 104°.10' of East Longitude

103°.45' - 104°.10' Bujur Timur

Master Plan of Batam - Rempang - Galang (Barelang)

Master Plan Batam - Rempang - Galang (Barelang)

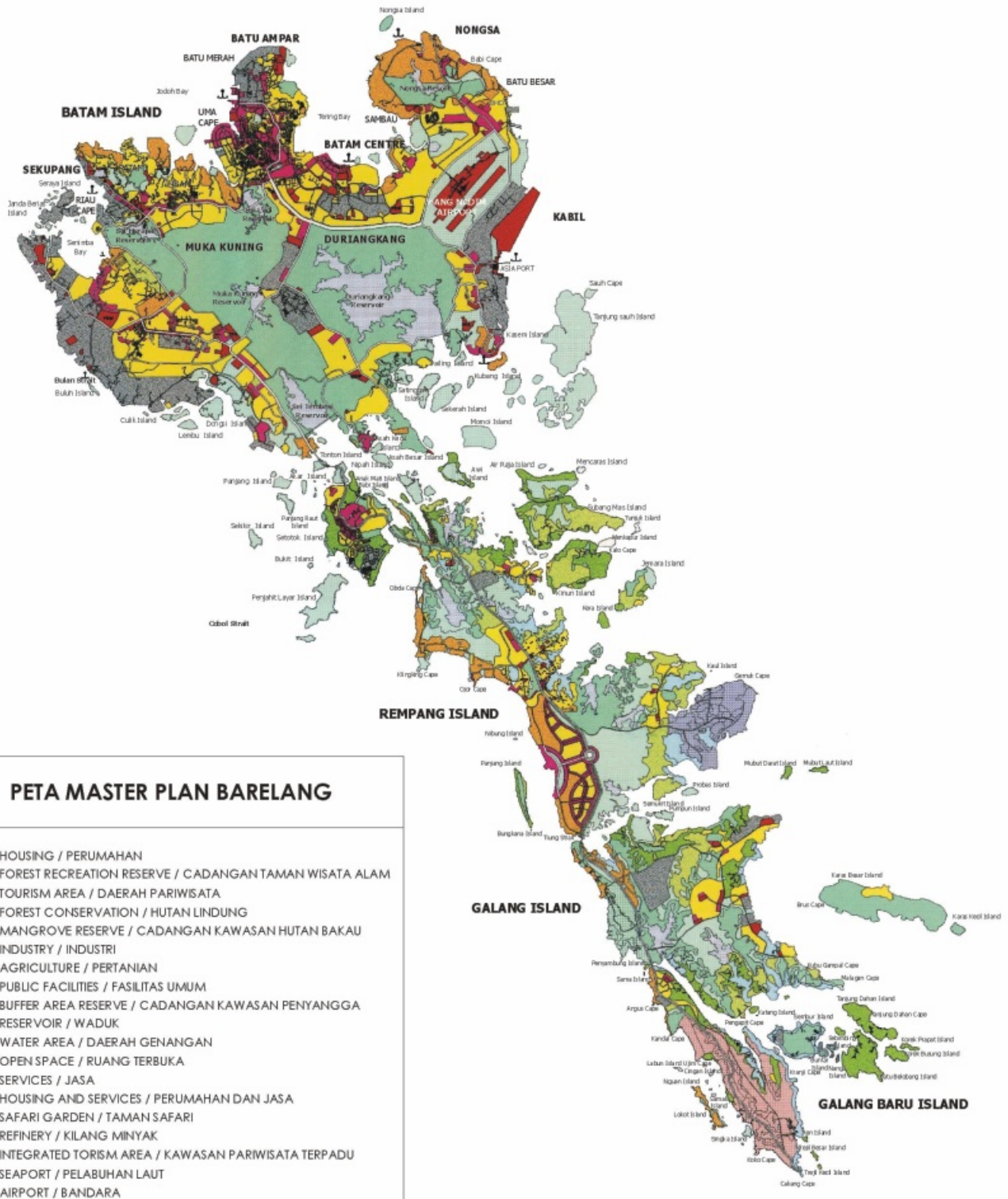

Geographic Data

Data Geografis

Batam Island Pulau Batam	415 Square Km (41,500 Ha) = 64% of Singapore 415 Km ² (41.500Ha) = 64% x luas Singapura
Singapore Singapura	Located 20 Km North-West of Batam Island, 647 Square Km (64,700 HA) Terletak 20 Km disebelah Barat Laut Pulau Batam, luas 647 Km ² (64.700Ha)
Bintan Island Pulau Bintan	Located 10 Km East of Batam Island, 1,100 Square Km (110,000 HA) = 170% of Singapore Terletak 10 Km disebelah Timur Pulau Batam, luas 1.100 Km ² (110.000Ha) = 170% luas Singapura
Natuna Island Pulau Natuna	Located 550 Km North-East of Batam Island, 1,720 Square Km (172,000 HA) = 266% of Singapore Terletak 550 Km disebelah Timur Laut Pulau Batam, luas 1.720 Km ² (172.000Ha) = 266% luas Singapura
Bulan Island Pulau Bulan	Located 2,5 Km South-West of Batam Island, 100 Square Km (10,000 HA) = 15% of Singapore Terletak 2,5 Km disebelah Barat Daya Pulau Batam, luas 100 Km ² (10.000Ha) = 15% luas Singapura
Rempang Island Pulau Rempang	Located 2,5 Km South-East of Batam Island, 165,83 Square Km (16,583 HA) = 26% of Singapore Terletak 2,5 Km disebelah Tenggara Pulau Batam, luas 165,83 Km ² (16.583Ha) = 26% luas Singapura
Galang Island Pulau Galang	Located 350 m South-East of Rempang Island, 80 Square Km (8,000 HA) = 12% of Singapore Terletak 350 m disebelah Tenggara Pulau Rempang, luas 80 Km ² (8.000Ha) = 12% luas Singapura
Galang Baru Island Pulau Galang Baru	Located 180 m South of Galang Island, 32 Square Km (3,200 HA) = 5% of Singapore Terletak 180 m disebelah Selatan Pulau Galang, luas 32 Km ² (3.200Ha) = 5% luas Singapura
Barelang Area Wilayah Barelang	Batam, Rempang, Galang and Surrounding Islands 715 Square Km (71,500 HA) = 110% of Singapore Pulau Batam, Rempang, Galang dan Pulau-Pulau disekitarnya 715 Km ² (71.500 Ha) = 110% x luas Singapura





Legal Platform of The Batam Industrial Development Authority

Landasan Hukum Otorita Batam

Presidential Decree No 74, 1971 KEPPRES No 74, 1971	The Development of Batam Island <i>Pengembangan Pembangunan Pulau Batam</i>
Presidential Decree No 41, 1973 KEPPRES No 41, 1973	Batam Industrial Area <i>Daerah Industri Pulau Batam</i>
Presidential Decree No 33, 1974 KEPPRES No 33, 1974	Appointment and Establishment of Bonded Warehouse on Batam Island <i>Penunjukan dan Penetapan Beberapa Wilayah Usaha Bonded Warehouse di Daerah Pulau Batam</i>
Decree of The Minister of Home Affairs No 43, 1977 SK MENDAGRI No 43, 1977	Management and Land Use Rights for Batam Island <i>Pengelolaan dan Penggunaan Tanah di Daerah Industri Pulau Batam</i>
Presidential Decree No 41, 1978 KEPPRES No 41, 1978	Establishment of Batam Island as Bonded Warehouse <i>Penetapan Seluruh Daerah Industri Pulau Batam Sebagai Wilayah Usaha Bonded Warehouse</i>
State Regulation No 34, 1983 Peraturan Pemerintah No 34, 1983	Establishment of Batam Island as Municipality within Riau Province <i>Pembentukan Kotamadya Batam di Wilayah Propinsi Daerah Tingkat I Riau</i>
Presidential Decree No 7, 1984 KEPPRES No 7, 1984	Working Relationship between Batam Municipality and Batam Industrial Development Authority <i>Hubungan Kerja Antara Kotamadya Batam dengan Otorita Pengembangan Daerah Industri Pulau Batam</i>
Presidential Decree No 56, 1984 KEPPRES No 56, 1984	Expansion of Batam Industrial Working Area and its Status as Bonded Warehouse <i>Penambahan Wilayah Lingkungan Kerja Daerah Industri Pulau Batam dan Penetapannya sebagai Wilayah Usaha Bonded Warehouse</i>
Presidential Decree No 28, 1992 KEPPRES No 28, 1992	Further Expansion of Batam Industrial Working Area and its Status as Bonded Zone <i>Penambahan Wilayah Lingkungan Kerja Daerah Industri Pulau Batam dan Penetapannya sebagai Wilayah Usaha Kawasan Berikat</i>
Decree of Chairman of National Land Agency No 9-VIII-1993 SK KETUA BPN No 9-VIII-1993	Management and Land Use Rights for Rempang, Galang and Surrounding Islands <i>Pengelolaan dan Pengurusan Tanah di Daerah Industri Pulau Rempang, Pulau Galang dan Pulau-Pulau disekitarnya</i>
Presidential Decree No 94, 1998 KEPPRES No 94, 1998	Improvement to Presidential Decree No 41 Year 1973 Concerning Batam Industrial Area <i>Penyempurnaan atas Keputusan Presiden Nomor 41 Tahun 1973 tentang Daerah Industri Pulau Batam</i>
State Law No 53, 1999 UU No 53, 1999	Establishment of Batam City as an Autonomous Region and positioning of Batam Industrial Development Authority as a Partner of Batam City in The Development of Batam <i>Pembentukan Kota Batam dan Kedudukan Badan Otorita Batam dalam Pembangunan Batam</i>
Joint Decree of the Batam Municipality & BIDA No 05/SKB/HK/VI/2000 Keputusan Bersama Walikota Batam & Ka. OB No 05/SKB/HK/VI/2000	Establishment of Working Committee for the Drafting of the Government Regulation on the Working Relationship Batam between Municipality and BIDA <i>Pembentukan dan Susunan Tim Perancang Draft Peraturan pemerintah Tentang Pengaturan Hubungan kerja Pemerintah Kota Batam dengan Badan Otorita Batam</i>
Presidential Decree No.113, 2000 Keppres. RI No 113, 2000	The Fourth Revision of Presidential Decree No.41 Year 1973. Concerning Batam Industrial Area <i>Perubahan keempat atas Keppres RI No.41 tahun 1973. Tentang Daerah Industri Pulau Batam</i>

Development Periods of Batam

Periode Pembangunan Daerah Industri Pulau Batam

1971 - 1976	Oil Based Period Chairman: Dr. Ibnu Sutowo Periode Persiapan Ketua : Dr. Ibnu Sutowo	
1976 - 1978	Consolidation Chairman: Prof. Dr. J.B. Sumarlin Periode Konsolidasi Ketua : Prof. Dr. J.B. Sumarlin	
1978 - 1998	Infrastructure and Capital Investment Development Chairman: Prof. DR. ING. B.J. Habibie Periode Pembangunan Prasarana dan Penanaman Modal Ketua : Prof. DR. ING. B.J. Habibie	
March 1998 - July 1998	Continuation of Infrastructure and Capital Investment Development Chairman: J.E. Habibie Periode Pembangunan Prasarana dan Penanaman Modal Lanjutan Ketua : J.E. Habibie	
July 1998 - Now	Further Development of Batam with Focus on Social Development and Investment Climate Improvement Chairman: Ismeth Abdullah Periode Pengembangan Pembangunan Prasarana dan Penanaman Modal Lanjutan Dengan Perhatian Lebih Besar Pada Kesejahteraan Rakyat dan Perbaikan Iklim Investasi Ketua : Ismeth Abdullah	

Batam Industrial Development Authority Organizational Chart

Struktur Organisasi Otorita Pengembangan Daerah Industri Pulau Batam

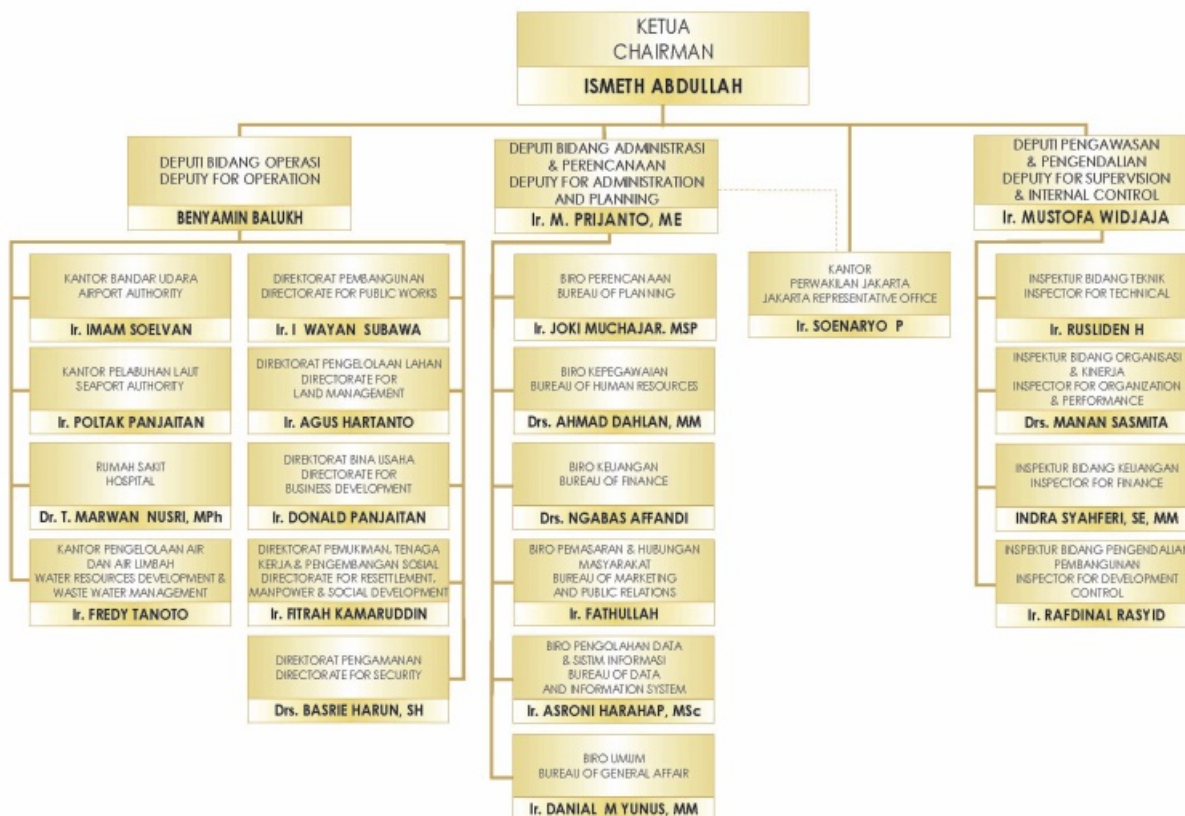

Population and Work Force

Penduduk dan Tenaga Kerja

Population Penduduk

Up to December 2002
s/d Desember 2002

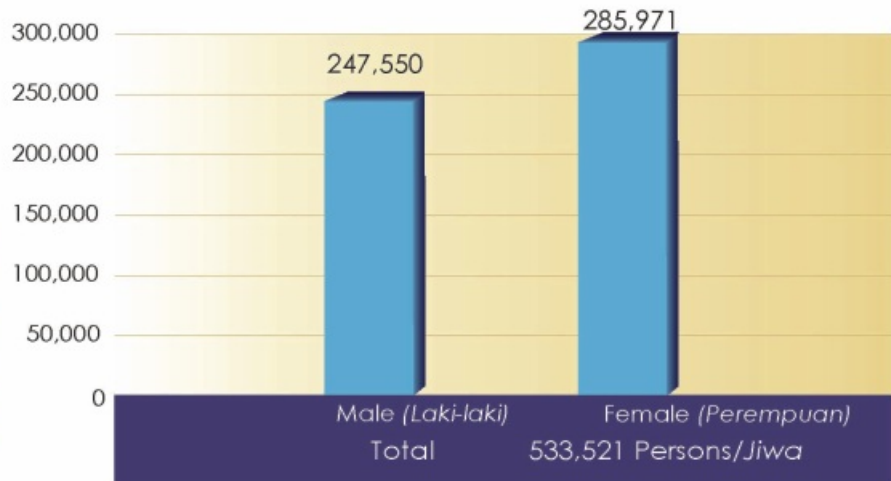

Projected population 2005, *750,000 persons
Proyeksi Penduduk Menjelang Tahun 2005, *750.000 jiwa

Source : Batam Demography and Settlements Office
Sumber Data : Dinas Kependudukan Kota Batam

Population Growth Pertumbuhan Penduduk

Up to December 2002
s/d Desember 2002

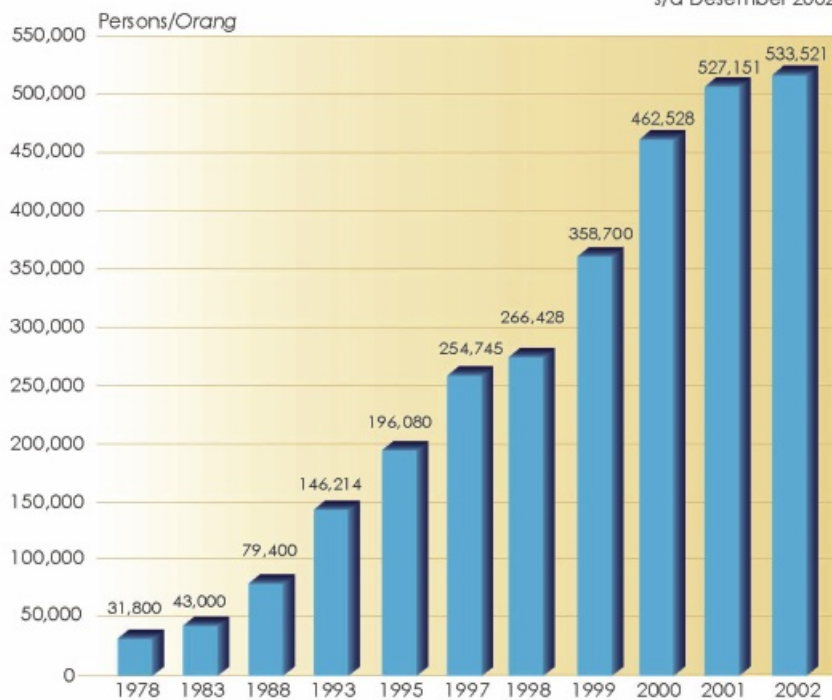

Source : Batam Demography and Settlements Office
Sumber Data : Dinas Kependudukan Kota Batam

Total Work Force Based on Business Sectors Jumlah Tenaga Kerja Menurut Sektor Lapangan Usaha

BUSINESS SECTOR SEKTOR USAHA	TOTAL COMPANIES JUMLAH PERUSAHAAN	TOTAL WORK FORCE JUMLAH TENAGA KERJA			
		INDONESIAN W N I		FOREIGN W N A	
		M/L	F/P	M/L	F/P
1. Agriculture Pertanian	23	1,765	103	3	-
2. Mining Pertambangan	24	380	59	129	-
3. Industry Industri	644	39,186	88,730	1,337	68
4. Electricity, Gas, Water Gas, Air, Listrik	12	649	29	8	-
5. Construction Bangunan	464	15,634	1,170	330	-
6. Trading, Hotels Perdagangan, Perhotelan	650	10,588	3,721	546	-
7. Transportation, Warehouse Pengangkutan, Pergudangan	150	557	471	87	-
8. Finance, Insurance Keuangan, Asuransi	86	1,640	333	3	-
9. Public Service Jasa Masyarakat	218	4,567	610	6	-
	2,271	74,966	95,226	2,449	68
TOTAL JUMLAH		170,192	2,517		
		172,709	PERSONS / ORANG		
TOTAL	: MALE / LAKI-LAKI	77,415	PERSONS/ ORANG (44,82 %)		
	: FEMALE / PEREMPUAN	95,294	PERSONS/ ORANG (55,18 %)		
TOTAL / JUMLAH		172,709	PERSONS/ ORANG		



Source : Batam Labour Office
Sumber Data : Dinas Tenaga Kerja Kota Batam

Work Force Growth Perkembangan Tenaga Kerja



Source : Batam Labour Office
Sumber Data : Dinas Tenaga Kerja Kota Batam



Roads and Bridges

Jalan dan Jembatan

Roads Jalan Raya

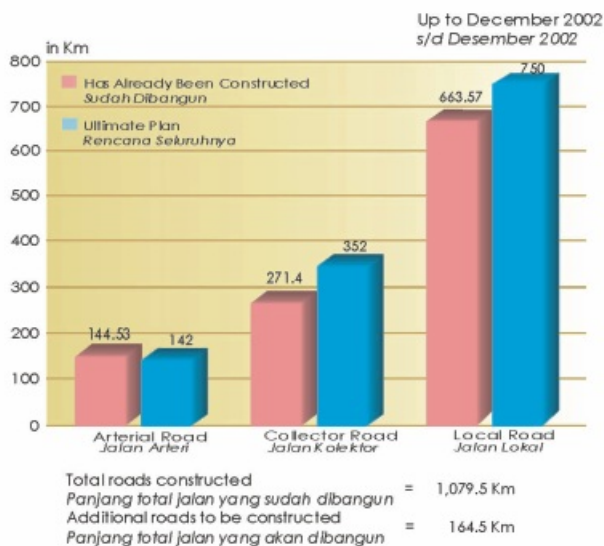

Bridges Jembatan-jembatan di Bareleng

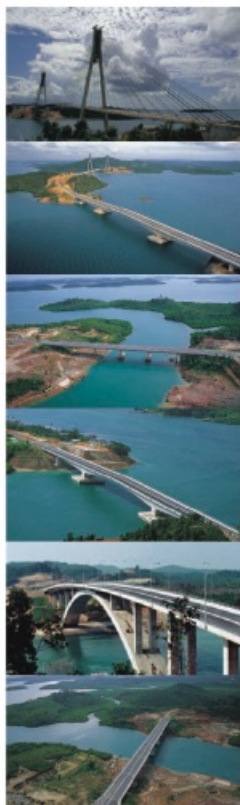

Bridges Name Nama Jembatan	Vertical Clearance (m) Tinggi Vertical (m)	Main Span (m) Bentang (m)	Total Span (m) Panjang Total (m)	Type of Bridge Tipe Jembatan
Tengku Fisabilillah Jembatan Tengku Fisabilillah Batam Island - Tonton Island Pulau Batam - Pulau Tonton	38	350	642	Cable Stayed Bridge
Nara Singa II Jembatan Nara Singa II Tonton Island - Nipah Island Pulau Tonton - Pulau Nipah	15	160	420	Balance Cantilever Concrete Box Girder Single Box
Raja Ali Haji Jembatan Raja Ali Haji Nipah Island - Setoko Island Pulau Nipah - Pulau Setoko	15	45	270	Segmental Concrete Box Girder
Sultan Zainal Abidin Jembatan Sultan Zainal Abidin Setoko Island - Rempang Island Pulau Setoko - Pulau Rempang	16.5	145	365	Balance Cantilever Concrete Box Girder Double Box
Tuanku Tambusai Jembatan Tuanku Tambusai Rempang Island - Galang Island Pulau Rempang - Pulau Galang	31	245	385	Arch Bridge
Raja Kecil Jembatan Raja Kecil Galang Island - Galang Baru Island Pulau Galang - Pulau Galang Baru	9.5	45	180	Segmental Concrete Box Girder

Seaport Facilities

Pelabuhan Laut

DATA	CONDITION KONDISI	SEKUPANG	BATU AMPAR	KABIL
BERTH CAPACITY (DWT) KAPASITAS SANDAR KAPAL	EXISTING SAAT INI	10,000	35,000	35,000
	FINAL DESIGN RENCANA AKHIR	15,000	35,000	150,000
BERTH LENGTH (m) PANJANG DERMAGA (m)	EXISTING SAAT INI	177	1,250	420
	FINAL DESIGN RENCANA AKHIR	1,200	3,600	5,500
BASIN DEPTH (m) KEDALAMAN PADA SISI DERMAGA (m)	EXISTING SAAT INI	9	14	13
	FINAL DESIGN RENCANA AKHIR	12	14	18
OPEN STORAGE (m ²) GUDANG TERBUKA (m ²)	EXISTING SAAT INI	116,100	214,000	100,000
	FINAL DESIGN RENCANA AKHIR	143,600	230,950	2,500,000 TEUS
WARE HOUSE (m ²) GUDANG TERTUTUP (m ²)	EXISTING SAAT INI	42,240	19,500	1,890
	FINAL DESIGN RENCANA AKHIR	92,000	208,950	



Ship Calls

Kunjungan Kapal Laut

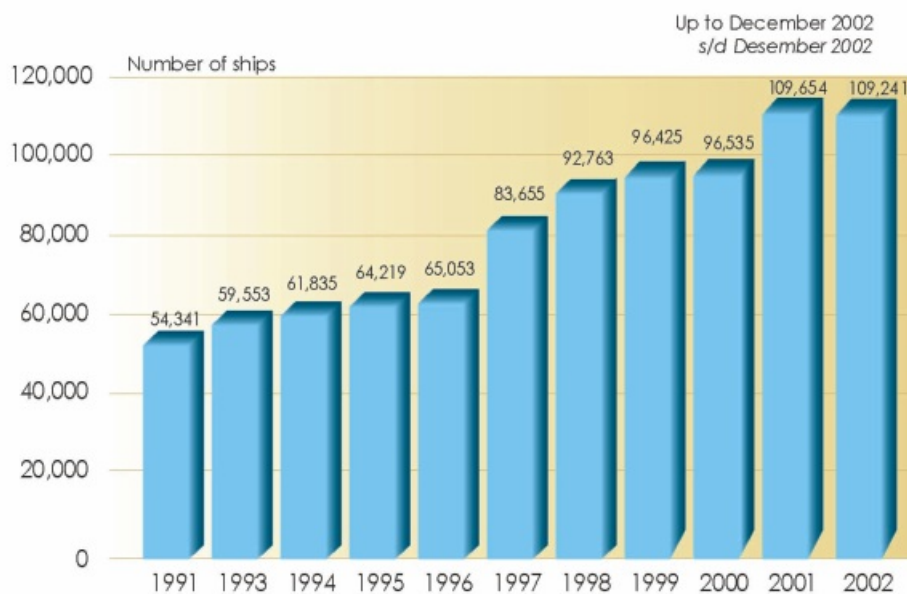

Batam Hang Nadim International Airport

Bandara Internasional Hang Nadim Batam



DATA	UNIT SATUAN	EXISTING SUDAH TERLAKSANA	ULTIMATE DESIGN RENCANA TAHAP AKHIR
RUNWAY LANDASAN PACU	m	4,000 X 45	4,000 X 45
APRON	m ²	130,500	170,000
TERMINAL	m ²	4 PAIRS OF BOARDING BRIDGE 31,500 (2 FLOOR) 4 GAR BARATA	12 PAIRS OF BOARDING BRIDGE 88,000 12 GAR BARATA
AIRCRAFT PESAWAT	TYPE	B-747	B-747
TERMINAL CAPACITY DAYA TAMPUNG TERMINAL	PASSENGER PER YEAR PENUMPANG / THN	3,300,000	8,300,000
STORAGE CAPACITY KAPASITAS PENYIMPANAN BARANG	TON	16,230	700,000
FUEL STORAGE CAPACITY KAPASITAS PENYIMPANAN BAHAN BAKAR	KILO LITRE	52,000	52,000

Aircraft Movement

Pergerakan Pesawat Udara

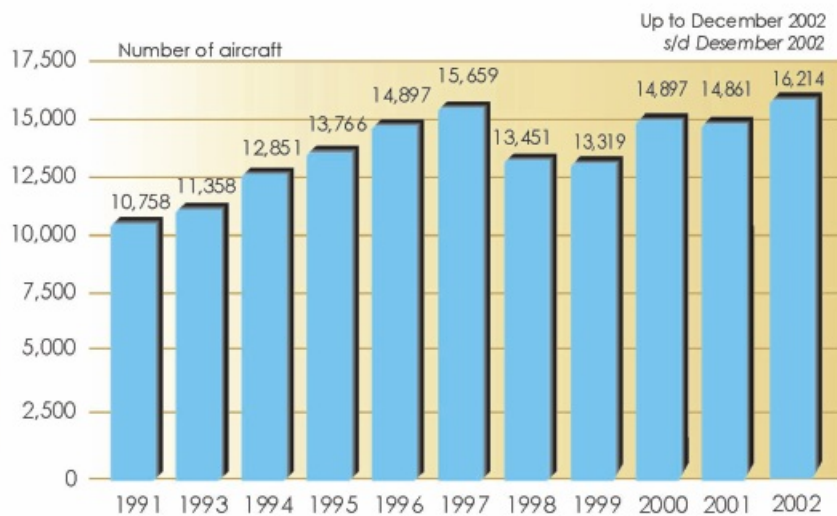

Electrical Power Supply Kelistrikan

1. State Owned Electrical Company Diesel Power Plant PLTD PLN	174 MW
2. Private Owned Electrical Company Diesel Power Plant PLTD SWASTA	203 MW
TOTAL	377 MW

Construction Plan Rencana Pembangunan

Middle Term Consumption Plan (2001/2005) Rencana Kebutuhan Jangka Menengah (2001/2005)	383,1 MW
Long Term Consumption Plan Rencana Kebutuhan Jangka Panjang	586,50 MW



A. Social Tariff/ Tarif Sosial

TARIFF CLASS GOLONGAN TARIF	POWER UNIT DAYA	CHARGE COST (Rp./kVA/Month BIAYA BEBAN (Rp./kVA/bulan)	USAGE COST (Rp/kWh) BIAYA PEMAKAIAN (Rp/kWh)	
			FROM NOV '01 MULAI NOP'01	FROM JAN '02 MULAI JAN'02
S-1/TR	220 VA	-		
S-2/TR	450 VA - 900 VA 1,300 VA - 2,200 VA	As TDL PT.PLN (Persero) Sesuai TDL PT.PLN (Persero)	As TDL PT.PLN (Persero) Sesuai TDL PT.PLN (Persero)	
	2,201 VA - 200kVA	14,000	Blok I : < 60 operation hour Blok I : < 60 jam operasi	190 238
S-3/TM	Above 200 kVA Diatas 200 kVA	15,500	Blok II : > 60 operation hour & next Blok II : > 60 jam operasi berikutnya	307 356
			Blok WBP Blok LWBP	375 451

B. Industrial Tariff/ Tarif Industri

TARIFF CLASS GOLONGAN TARIF	POWER UNIT DAYA	CHARGE COST (Rp./kVA/Month BIAYA BEBAN (Rp./kVA/bulan)	USAGE COST (Rp/kWh) BIAYA PEMAKAIAN (Rp/kWh)	
			FROM NOV '01 MULAI NOP'01	FROM JAN '02 MULAI JAN'02
I-1/TR	450 VA - 900 VA	17,000	Blok I : < 120 operation hour Blok I : < 120 jam operasi	414 499
	1300 VA - 14 kVA	17,000	Blok II : > 120 operation hour & next Blok II : > 120 jam operasi berikutnya	448 570
I-2/TR	14 kVA - 200kVA	18,000	Blok I : < 120 operation hour Blok I : < 120 jam operasi	439 499
			Blok II : > 120 operation hour & next Blok II : > 120 jam operasi berikutnya	458 570
I-3/TR	200 kVA - 30,000 kVA	16,000	Blok I WBP Blok I LWBP	439 534
			Blok I LWBP	429 509
I-3/TR	Above 30,000 kVA Diatas 30,000 kVA	15,500	< 350 operation hour / jam operasi, Blok WBP	458 565
			> 350 operation hour / jam operasi, Blok WBP	468 565
				448 524

C. Business Tariff/ Tarif Bisnis

TARIFF CLASS GOLONGAN TARIF	POWER UNIT DAYA	CHARGE COST (Rp./kVA/Month BIAYA BEBAN (Rp./kVA/bulan)	USAGE COST (Rp/kWh) BIAYA PEMAKAIAN (Rp/kWh)	
			FROM NOV '01 MULAI NOP'01	FROM JAN '02 MULAI JAN'02
B-1/TR	250 VA - 900 VA	16,500	Blok I : < 120 operation hour Blok I : < 120 jam operasi	287 342
	1,300 VA - 2,200 VA	16,500	Blok II : > 120 operation hour & next Blok II : > 120 jam operasi berikutnya	439 518
Blok I : < 120 operation hour Blok I : < 120 jam operasi			449 518	
B-2/TR	2,201 VA - 200 kVA	19,000	Blok II : > 120 operation hour & next Blok II : > 120 jam operasi berikutnya	511 613
			Blok I : < 100 operation hour Blok I : < 100 jam operasi	449 536
B-3/TR	Above 6,600 kVA Diatas 6,600 kVA	16,500	Blok II : > 100 operation hour & next Blok II : > 100 jam operasi berikutnya	511 602
			Blok I WBP Blok I LWBP	433 538

Note : Tariff may change subject to service provider
Catatan : Tarif dapat berubah sesuai tarif pada penyedia layanan

TDL = Basic Electric Tariff
TDL = Tarif Dasar Listrik

Water Supply

Air Bersih

Tariff (Rp)/m³
Tarif (Rp)/m³

	SOCIAL SOSIAL	HOUSING PERUMAHAN	GOVERNMENT PEMERINTAH	LOW-COST HOUSING PERUMAHAN MURAH	LIGHT COMMERCIAL PERNIAGAAN KECIL	COMMERCIAL PERNIAGAAN	LIGHT INDUSTRY INDUSTRI KECIL	INDUSTRY INDUSTRI	SPECIAL KHUSUS
> 0 - 20 (m ³)	510	525	700	290	1650	1650	5000	7500	8125
21 - 40 (m ³)	510	1250	1250	385	2875	3750	5000	7500	8125
> 40 (m ³)	510	3250	3250	1025	4900	5880	5000	7500	8125

Note : Tariff may change subject to service provider
Catatan : Tarif dapat berubah sesuai tarif pada penyedia layanan

Fresh Water Supply Penyediaan Air Bersih

	VOLUME	WTP CAPACITY KAPASITAS WTP	OPERATIONAL OPERASI
BALOI RESERVOIR WADUK BALOI	200,000 m ³	60 L/ SEC 60 L/ DETIK	60 L/ SEC 60 L/ DETIK
SEI LADI RESERVOIR WADUK SEI LADI	8,800,000 m ³	280 L/ SEC 280 L/ DETIK	325 L/ SEC 325 L/ DETIK
SEI HARAPAN RESERVOIR WADUK SEI HARAPAN	4,800,000 m ³	210 L/ SEC 210 L/ DETIK	190 L/ SEC 190 L/ DETIK
NONGSA RESERVOIR WADUK NONGSA	700,000 m ³	100 L/ SEC 100 L/ DETIK	95 L/ SEC 95 L/ DETIK
DURIANGKANG & TANJUNG PIAYU RESERVOIR WADUK DURIANGKANG & TANJUNG PIAYU	62,000,000 m ³	3,000 L/ SEC 3,000 L/ DETIK	525 L/ SEC 270 L/ SEC 525 L/ DETIK 270 L/ DETIK
MUKAKUNING RESERVOIR WADUK MUKAKUNING	13,400,000 m ³	310 L/ SEC 310 L/ DETIK	295 L/ SEC 295 L/ DETIK
TOTAL VOLUME JUMLAH VOLUME AIR WADUK	89,900,000 m ³		
TOTAL PLANNED WTP CAPACITY KAPASITAS RENCANA WTP SELURUHNYA		3,960 L/ SEC 3,960 L/ DETIK	
EXISTING WTP CAPACITY KAPASITAS WTP TERSEDIA			1,760 L/ SEC 1,760 L/ DETIK



Telecommunication

Telekomunikasi

Source : Telkom Batam
Sumber Data : Telkom Batam

1. FACILITIES AND INFRASTRUCTURE FASILITAS DAN INFRASTRUKTUR

A. AUTOMATIC CENTRAL TELEPHONE SENTRAL TELEPON OTOMAT	18	Locations Lokasi
B. CENTRAL CAPACITY KAPASITAS SENTRAL	61,460	Line Units Satuan sambungan
	19,000	Code Division Multiple Access (CDMA) Code Division Multiple Access (CDMA)
C. TRANSMISSION CAPACITY KAPASITAS TRANSMISI	63	E1 E1
	12	Core Local Fibre Optic Core Serat Optik Lokal
	155	MBPS - Singapore MBPS - Singapura
	274	MBPS - Pekan Baru MBPS - Pekanbaru
D. NETWORK CAPACITY KAPASITAS JARINGAN	83,786	Line Units Satuan sambungan
E. IDLE CAPACITY KAPASITAS IDLE	9,273	Line Units Satuan sambungan
F. OPERATIONAL BEROPERASI	52,877	Line Units Satuan sambungan
G. INTERNET SERVICE PROVIDER PENYEDIA LAYANAN INTERNET		- TELKOMNET INSTAN - INDOSATNET - CBN - IDOLANET - CENTRIN - TRANSPERDANA INTI MAJU



3. TARIFF (Rp) TARIF (Rp)

	BUSINESS BISNIS	HOUSING PERUMAHAN	SOCIAL SOSIAL
Installation Pasang Baru	350,000	250,000	125,000
Monthly Fee Tarif Bulanan	38,500	23,000	13,750

Note : Tariff may change subject to service provider
Catatan : Tarif dapat berubah sesuai tarif pada penyedia layanan

2. CUSTOMERS PELANGGAN

A. BUSINESS BISNIS	17,038	Customers Pelanggan
B. HOUSING PERUMAHAN	31,593	Customers Pelanggan
C. SOCIAL SOSIAL	158	Customers Pelanggan
D. PUBLIC SERVICE PELAYANAN UMUM	2,938	Customers Pelanggan

4. PUBLIC PHONE IN BATAM TELEPON UMUM DI BATAM

TELCO RESELLER	TELECOMMUNICATION KIOSK WARTEL	PUBLIC PHONE	CALLING CARD
133	2086	479	240



Infrastructure of Information Technology

Infrastruktur Teknologi Informasi

Multimedia Network Infrastructure Infrastruktur Jaringan Multimedia

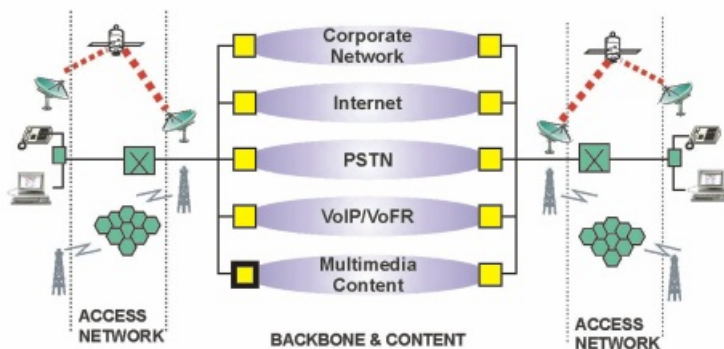

Batam Intelligent Island Batam Intelligent Island



National Pilot Project for a Comprehensive Implementation of e-Government, e-Business and e-Infrastructure Service
Proyek Percontohan Nasional yang Meliputi Pengembangan dalam Pelayanan e-Government, e-Business dan e-Infrastructure

PRIMARY LOOP JARINGAN UTAMA

Fibre Optic Backbone Network Connecting Government Institutions, Industrial Estates, Academic Institutions, R & D, Condominiums & Housing, Shopping Centres, Tourism & Services
Jaringan Serat Optik yang menghubungkan Institusi Pemerintah, Kawasan Industri, Pendidikan, Perumahan, Pusat Pembelian dan Pariwisata

BENEFITS KEUNTUNGAN

- Integrated Access Database
Akses database yang terintegrasi
- Easy Information Gathering
Kemudahan Mendapatkan Informasi
- Human Resources Improvement
Peningkatan Kualitas Sumber Daya Manusia
- Improvement of Public Services
Peningkatan Pelayanan Masyarakat
- Interactive Communication Media
Media Komunikasi Interaktif

Total Investment

Total Investasi

Up to December 2002
s/d Desember 2002

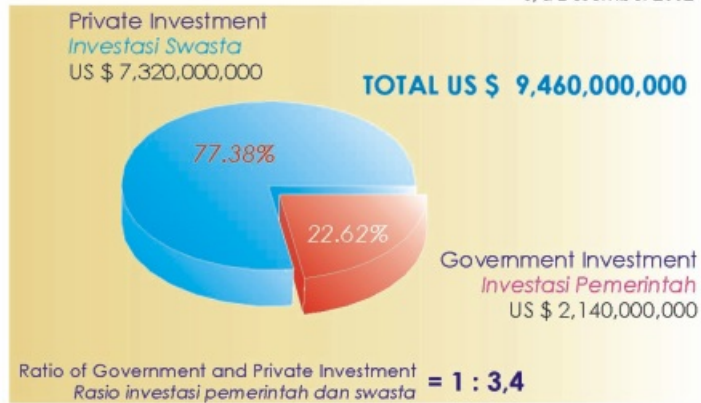

Comparison of Private Investment

Perbandingan Investasi Swasta

Up to December 2002
s/d Desember 2002



Government Investment *Investasi Pemerintah*

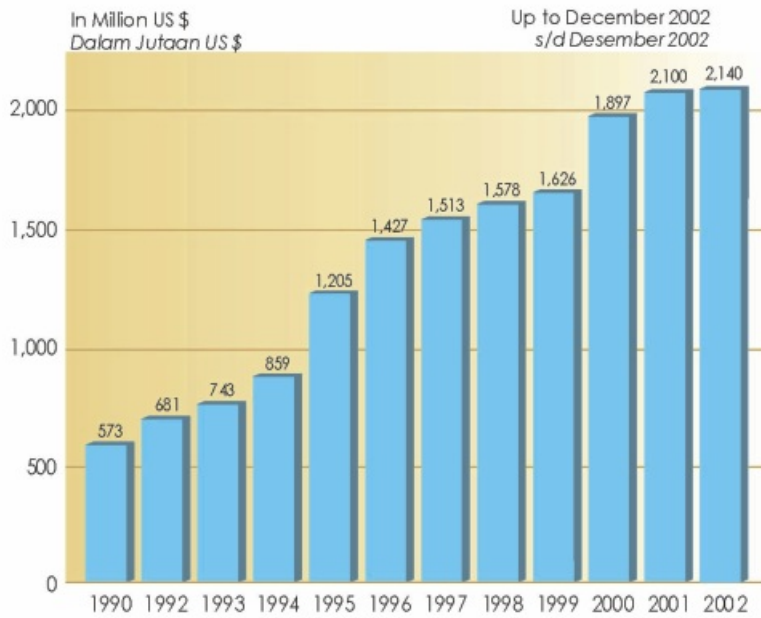

Domestic Private Investment *Investasi Swasta Domestik*

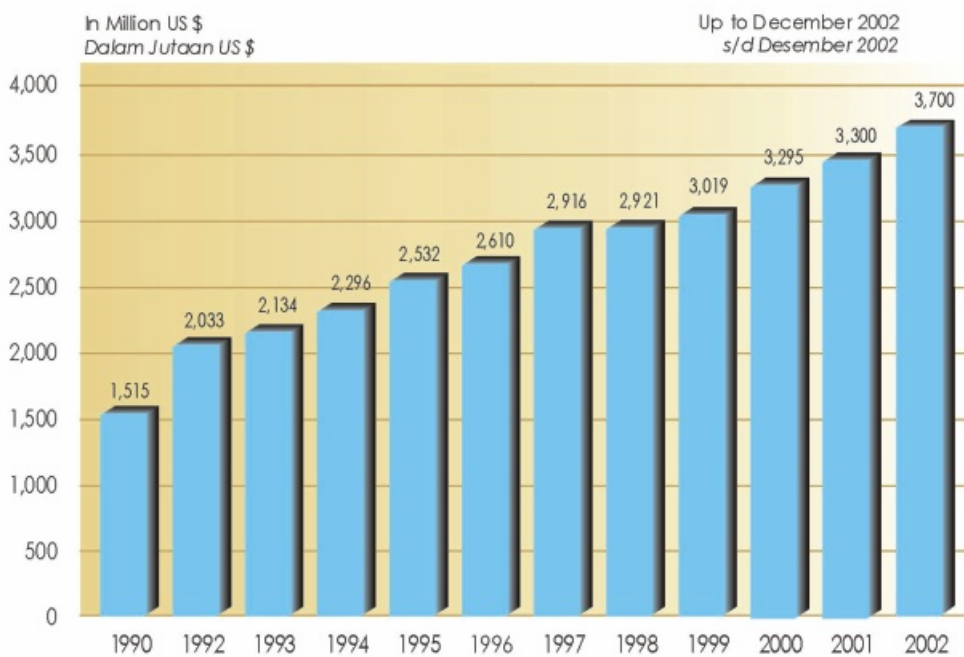

Foreign Private Investment Pertumbuhan Investasi Swasta Asing

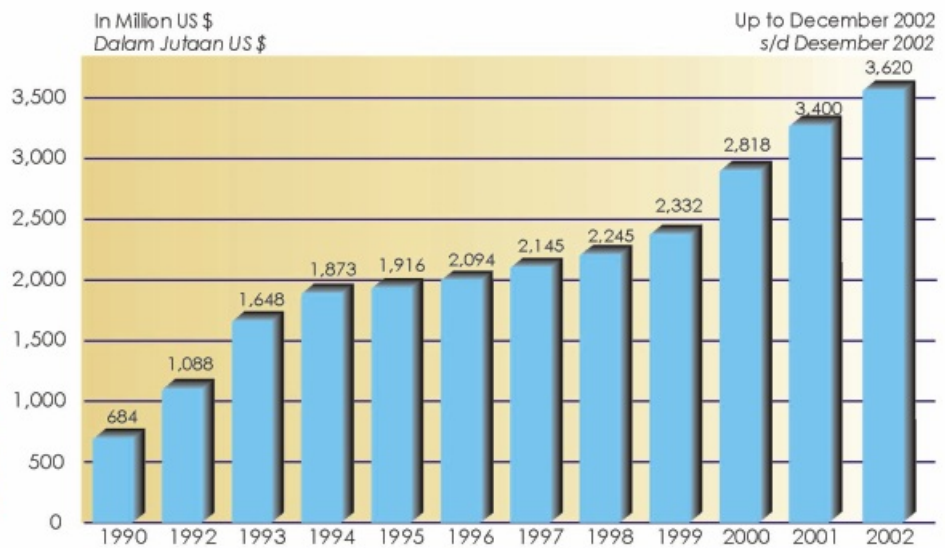

Comparison of Private Investment by Type of Business Perbandingan Investasi Swasta Menurut Jenis Kegiatan

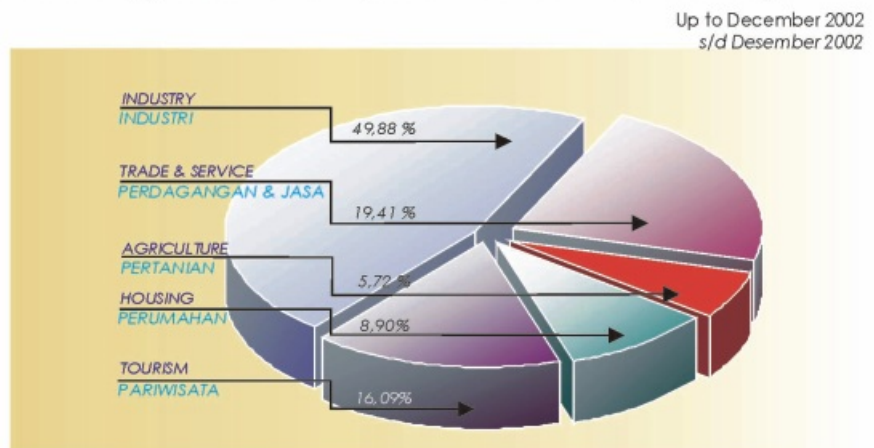

Private Investment (Domestic & Foreign) Total Pertumbuhan Investasi Swasta (Domestik & Asing)

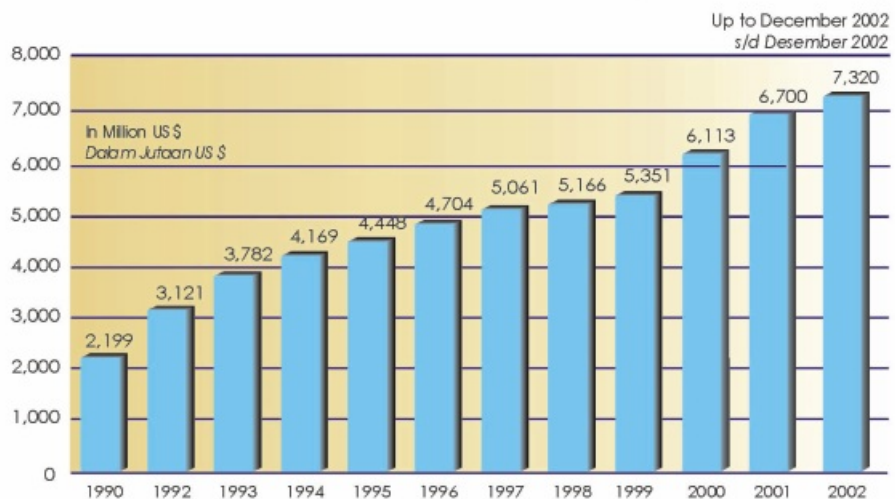

Export and Foreign Exchange Revenue

Ekspor dan Pemasukan Devisa

Export from Batam Ekspor dari Batam

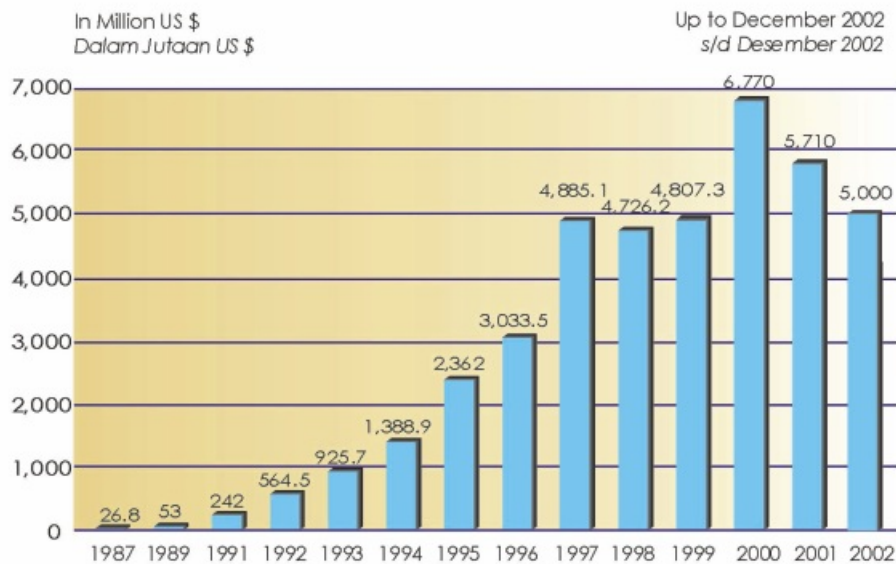

Source : Central Bureau of Batam
Sumber Data : Badan Pusat Statistik, Batam



Foreign Exchange Revenue Pemasukan Devisa

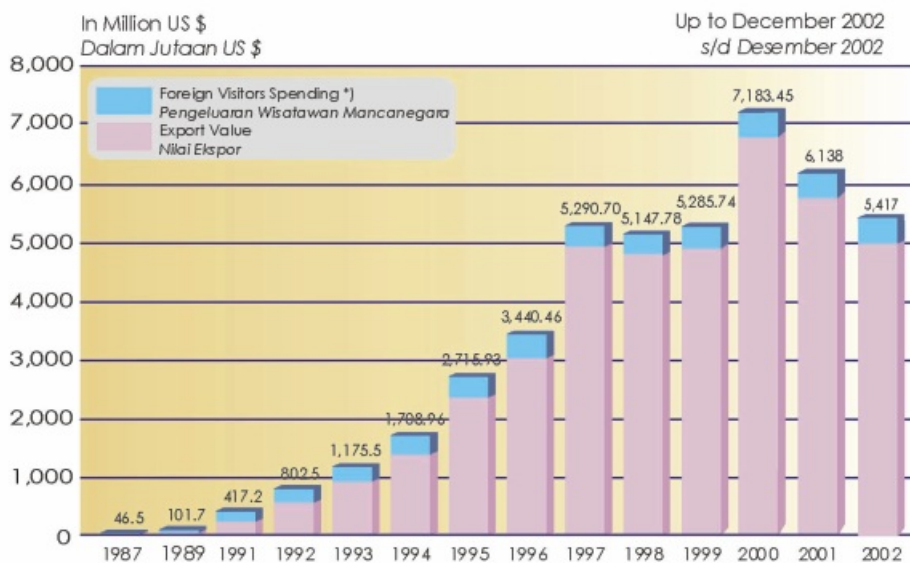

Source : Central Bureau of Batam
Sumber Data : Badan Pusat Statistik, Batam



Note : *) Refer to Foreign Visitors Spending in Batam, Page 24

Non Oil & Gas Export Value Comparison of Indonesia, Batam and Riau Province

Perbandingan Nilai Ekspor Non Migas Indonesia, Batam dan Propinsi Riau

In Million US \$
 Dalam Jutaan US \$

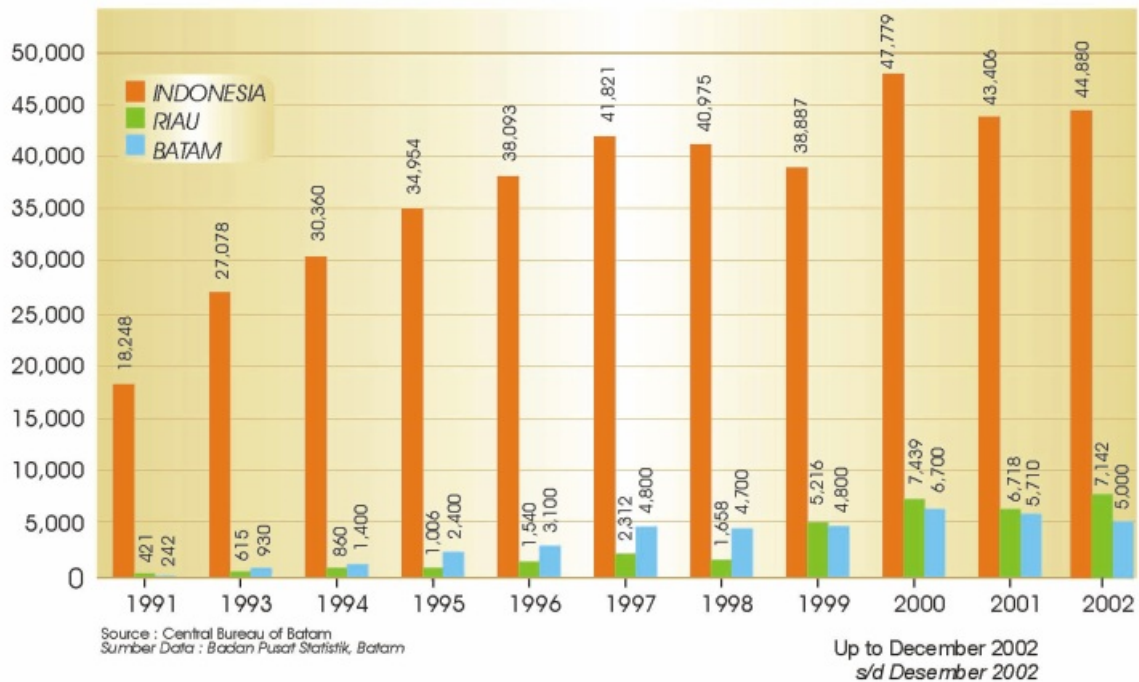

Tax Revenue

Penerimaan Pajak

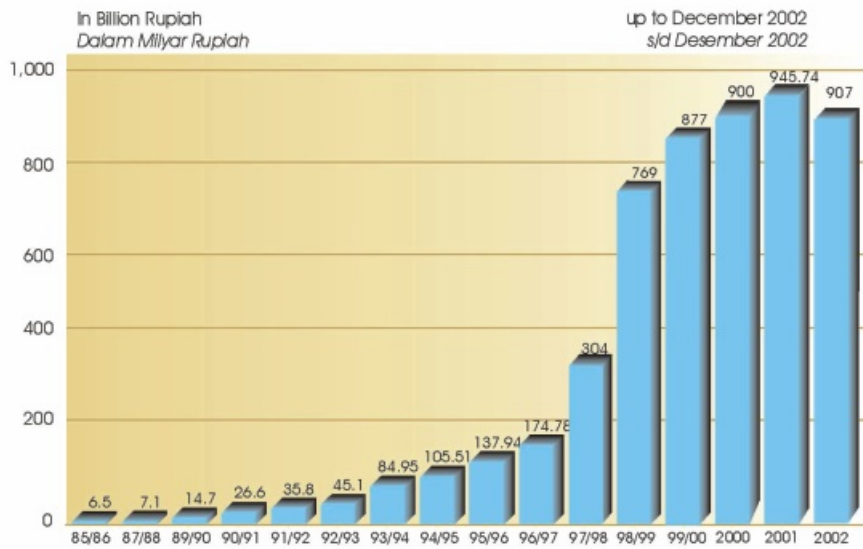

Source : Batam Taxation Office
Sumber Data : Kantor Pelayanan Pajak Batam

Tax Revenue from Batam Penerimaan Pajak dari Batam

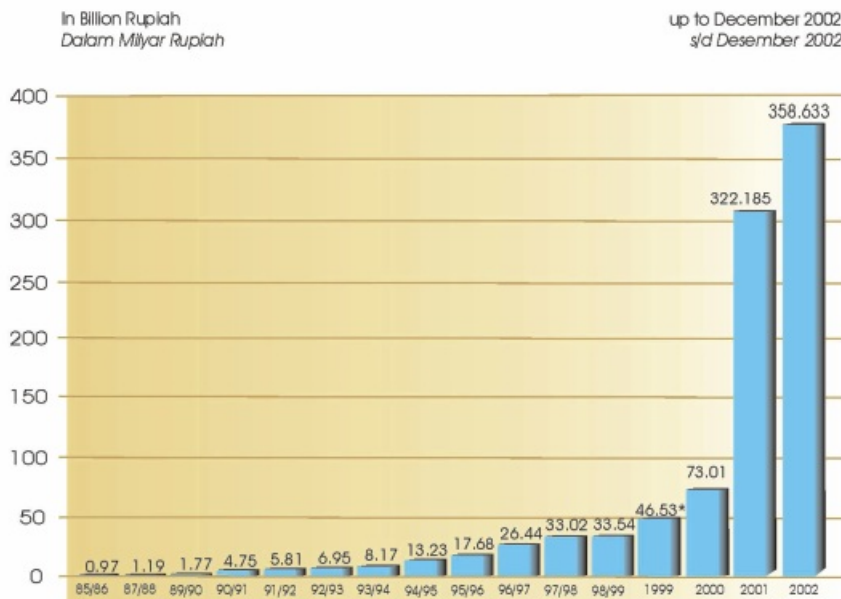

Source : Batam Municipality
Sumber Data : Pemko Batam

*] Jan '99 - Dec '00
Jan '99 - Des '00

City of Batam Revenue Penerimaan Kota Batam

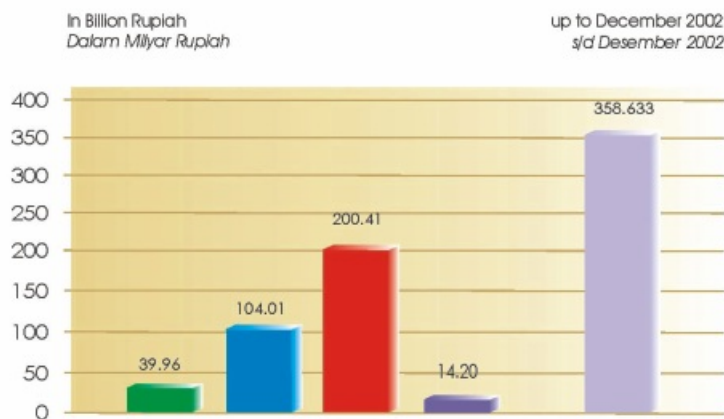

- **Remaining of Last Year budget**
Sisa lebih perhitungan anggaran tahun lalu
- **Batam Municipality Revenue**
Pendapatan Asli daerah
- **Government Support**
Dana Perimbangan
- **Other Revenues**
Penerimaan Lain
- **Total Revenue for City of Batam**
Total Penerimaan Kota Batam

Source : Batam Municipality
Sumber Data : Pemko Batam

Batam Economic Structure by Year

Struktur Ekonomi Batam per Tahun

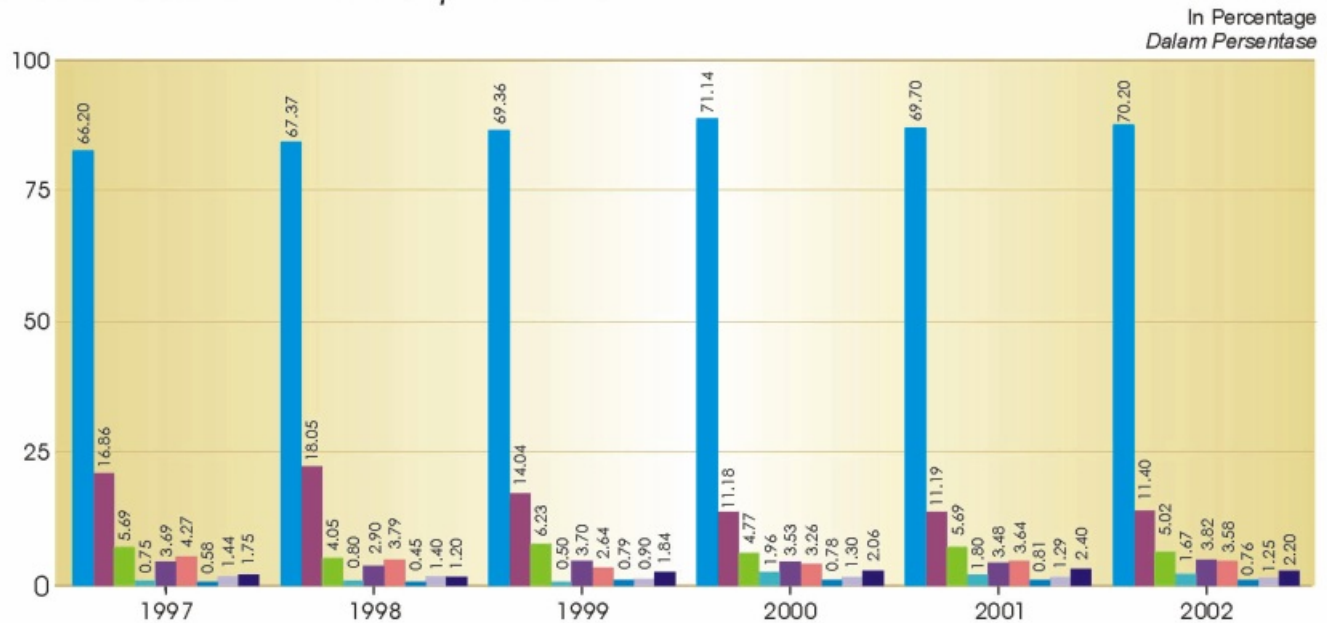

Source : Central Bureau of Batam
Sumber Data : Badan Pusat Statistik, Batam

- Industry - Industry
- Trade, Hotel & Restaurant - Perdagangan, Hotel dan Restoran
- Finance, Rental & Company Services - Keuangan, Persewaan dan Jasa Perusahaan
- Agriculture - Pertanian
- Shipping & Communication - Pengangkutan & Komunikasi
- Building & Construction - Bangunan & Konstruksi
- Mining & Dredging - Pertambangan & Penggalian
- Electricity & Water - Listrik & Air Bersih
- Services - Jasa - jasa

Batam Economic Structure 2002

Struktur Ekonomi Batam Tahun 2002

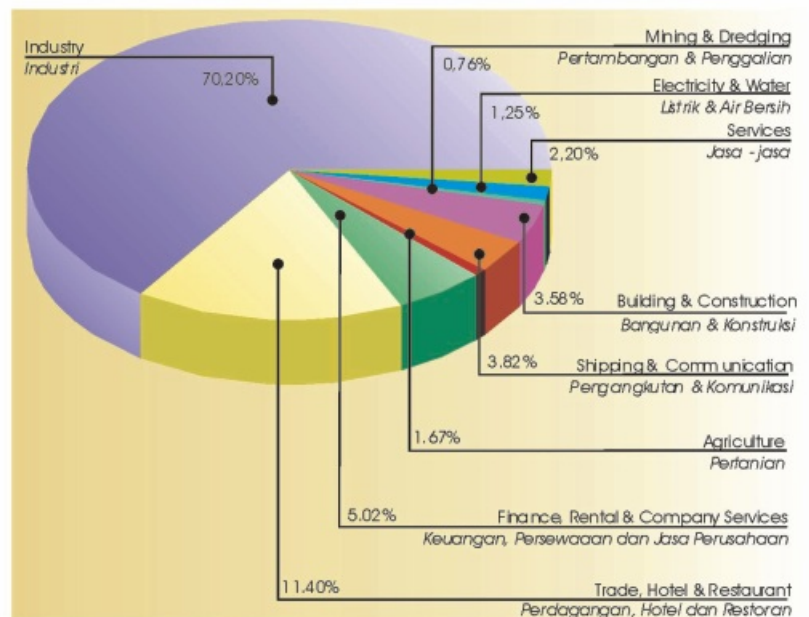

Source : Central Bureau of Batam
Sumber Data : Badan Pusat Statistik, Batam

Comparison of GDP per Capita of Indonesia and GRDP per Capita of Batam
 (Non Oil & Gas) 2002
 Perbandingan PDB Perkapita Indonesia dengan PDRB Perkapita Batam
 (Non Migas) Tahun 2002

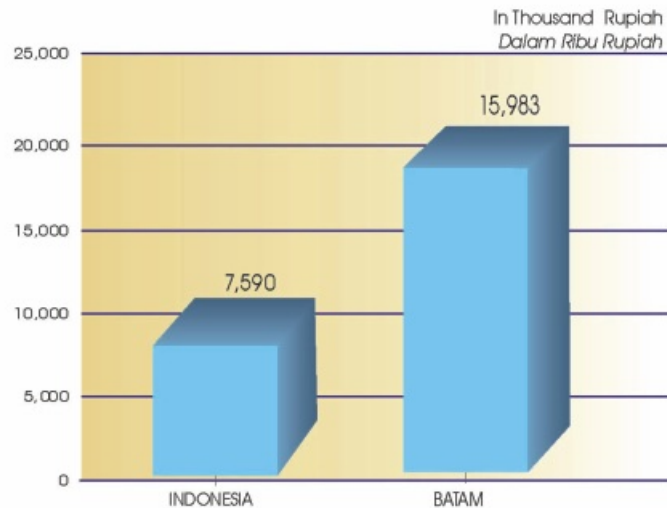

Source : Central Bureau of Batam
 Sumber Data : Badan Pusat Statistik, Batam

Foreign Visitor to Indonesia by Port of Arrival
 Kunjungan Wisatawan Mancanegara ke Indonesia Menurut Pintu Masuk

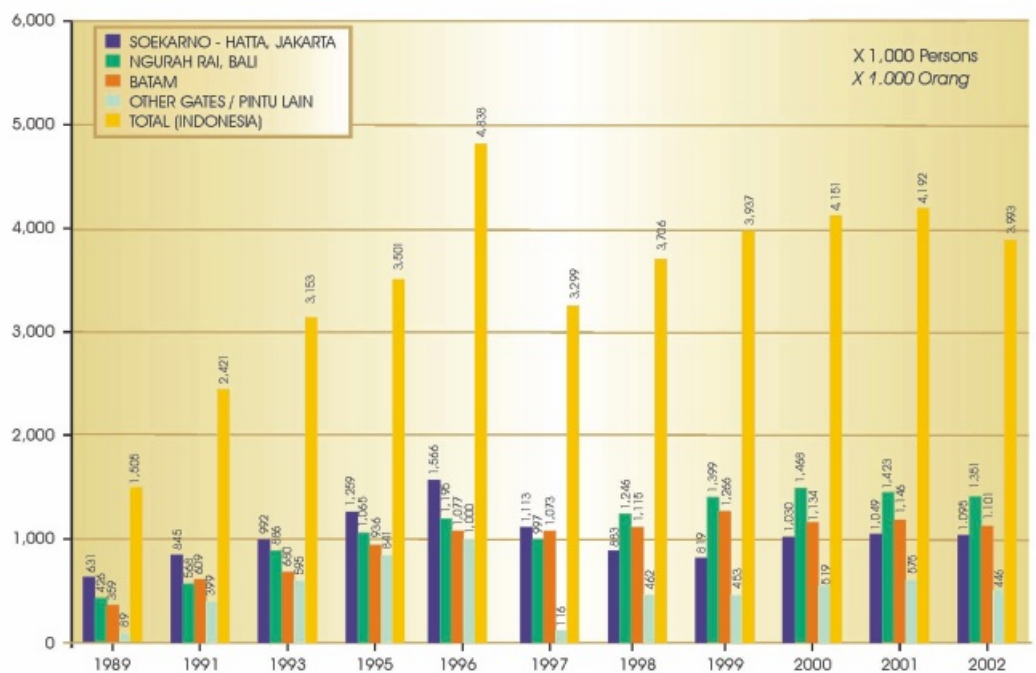

Source : Central Bureau of Batam
 Sumber Data : Badan Pusat Statistik, Batam

Foreign Visitors

Wisatawan Mancanegara

Foreign Visitors to Batam
Wisatawan Mancanegara ke Batam

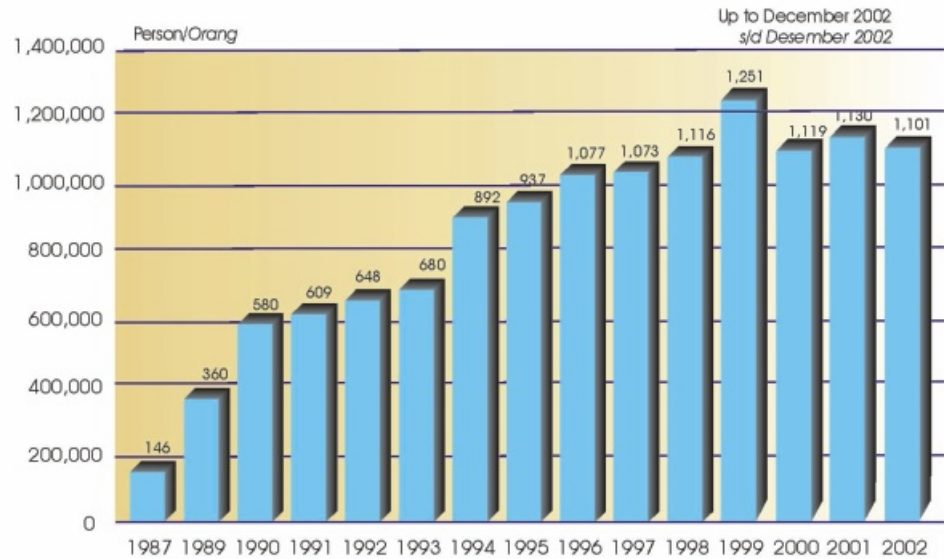

Source : Central Bureau of Batam
Sumber Data : Badan Pusat Statistik, Batam



Foreign Visitor Spending in Batam
Penerimaan Devisa dari Wisatawan Mancanegara di Batam

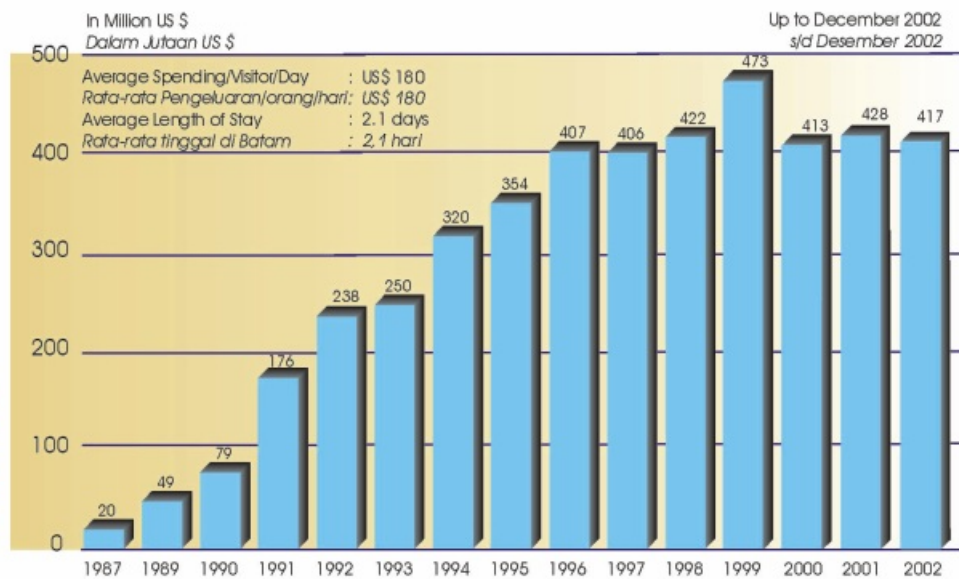

Source : Central Bureau of Batam
Sumber Data : Badan Pusat Statistik, Batam



Public Facilities

Fasilitas Umum

1. HOTELS				
A. STAR HOTELS HOTEL BERBINTANG	47	5,852	Rooms Kamar	
B. NON STAR HOTELS MELATI	111	2,662	Rooms Kamar	
C. MOTELS PENGINAPAN	44	936	Rooms Kamar	
TOTAL	198	9,450	Rooms Kamar	



2. BANKS		
A. GOVERNMENT PEMERINTAH	5	
B. PRIVATE SWASTA	14	
C. FOREIGN SWASTA ASING	2	
TOTAL	21	

3. INSURANCE COMPANIES PERUSAHAAN ASURANSI	9
4. SEA FREIGHT FORWARDERS EKSPEDISI MUJATAN KAPAL LAUT (EMKL)	27
5. AIR FREIGHT FORWARDERS EKSPEDISI MUJATAN KAPAL UDARA (EMKU)	5
6. TAXIS TAXIS	2,783
7. CITY BUS BUS KOTA	54
8. CINEMAS GEDUNG BIOSKOP	1
9. SHOPPING CENTRES PUSAT PERBELANJAAN	13
10. STREET MARKETS PASAR	17



Source : Central Bureau of Batam
Sumber Data : Badan Pusat Statistik, Batam

Social Facilities

Fasilitas Sosial

1. SCHOOLS SEKOLAH	
KINDERGARTENS TAMAN KANAK-KANAK	59
ELEMENTARY SCHOOLS SEKOLAH DASAR	142
SECONDARY SCHOOLS SEKOLAH LANJUTAN TINGKAT PERTAMA	28
HIGH SCHOOLS SEKOLAH MENENGAH UMUM / KEJURUAN	17
POLYTECHNICS POLITEKNIK	1
UNIVERSITIES/ COLLEGES PERGURUAN TINGGI/ AKADEMI	13



2. HEALTH FACILITIES FASILITAS KESEHATAN	
CLINICS AND PUBLIC HEALTH CENTRES POLIKLINIK DAN PUSKESMAS	104
HOSPITALS RUMAH SAKIT	6
MATERNITY HOSPITALS RUMAH SAKIT BERSALIN	16
PHARMACIES APOTIK	22
DRUG STORES TOKO OBAT	65

3. RELIGIOUS FACILITIES TEMPAT PERIBADATAN	
MOSQUES MESJID DAN MUSHOLLA	336
CHURCHES GEREJA	162
TEMPLES VIHARA	39



4. SPORTING FACILITIES FASILITAS OLAH RAGA	
SOCCER FIELDS LAPANGAN BOLA	4
GOLF COURSES LAPANGAN GOLF	6
TENNIS COURTS LAPANGAN TENIS (Fasilitas Hotel & Perumahan)	15

Sources : Central Bureau of Batam
Sumber Data : Badan Pusat Statistik, Batam

Joint Ventures Between Indonesia and Foreign Countries

Investasi PMA Joint Venture Dengan Indonesia

- Foreign Joint Ventures between Foreign Countries (Including Indonesia)
Tabel Investasi PMA Joint Venture (Dengan Indonesia)
- Foreign Joint Ventures between Foreign Countries (Not Including Indonesia)
Tabel Investasi PMA Joint Venture (Tidak Dengan Indonesia)
- Foreign Investment (one country)
Penanaman Modal Asing (satu negara)

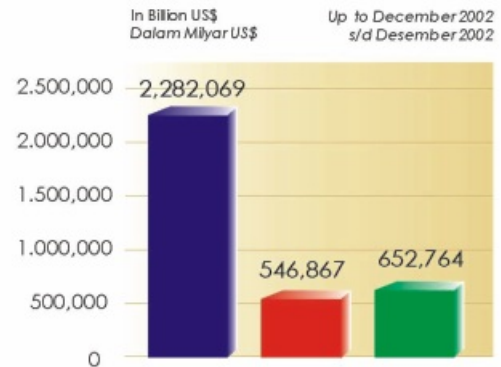

Foreign Joint Ventures between Foreign Countries (Including Indonesia) Tabel Investasi PMA Joint Venture (Dengan Indonesia)

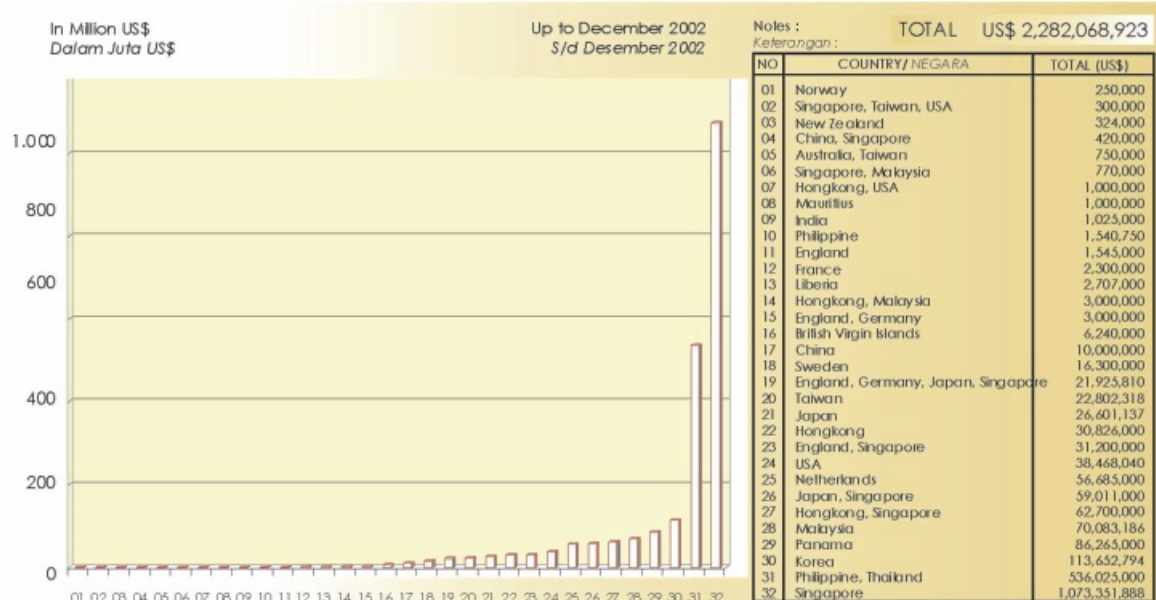

Foreign Joint Ventures between Foreign Countries (not Including Indonesia) Tabel Investasi PMA Joint Venture (Tidak Dengan Indonesia)

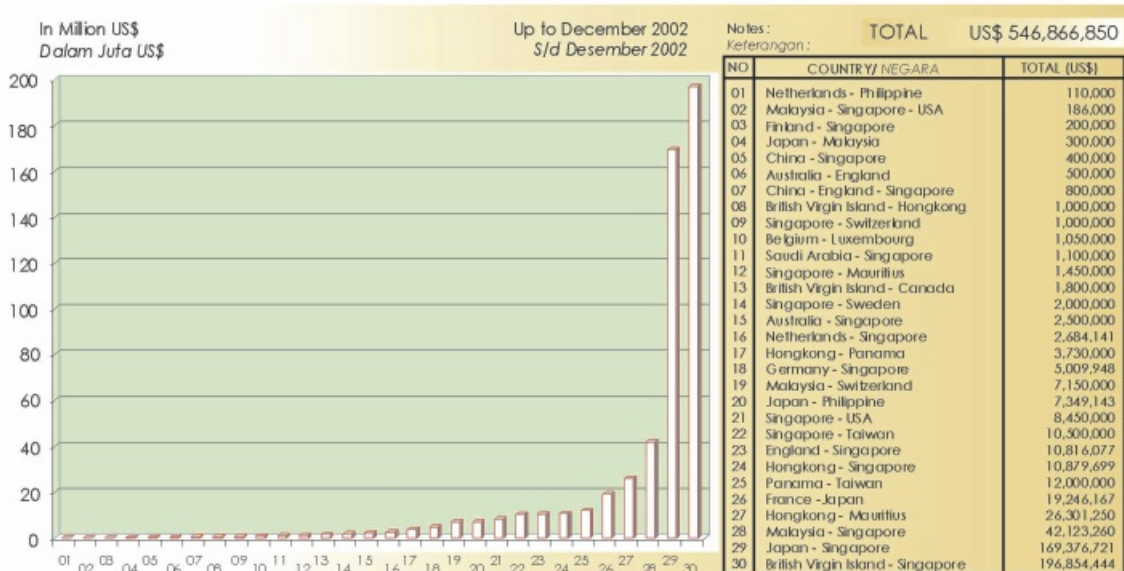

Value of Foreign Direct Investment by Country

Tabel Nilai Investasi PMA Berdasarkan Asal Negara

In Million US\$
Dalam Juta US\$

Up to December 2002
S/d Desember 2002

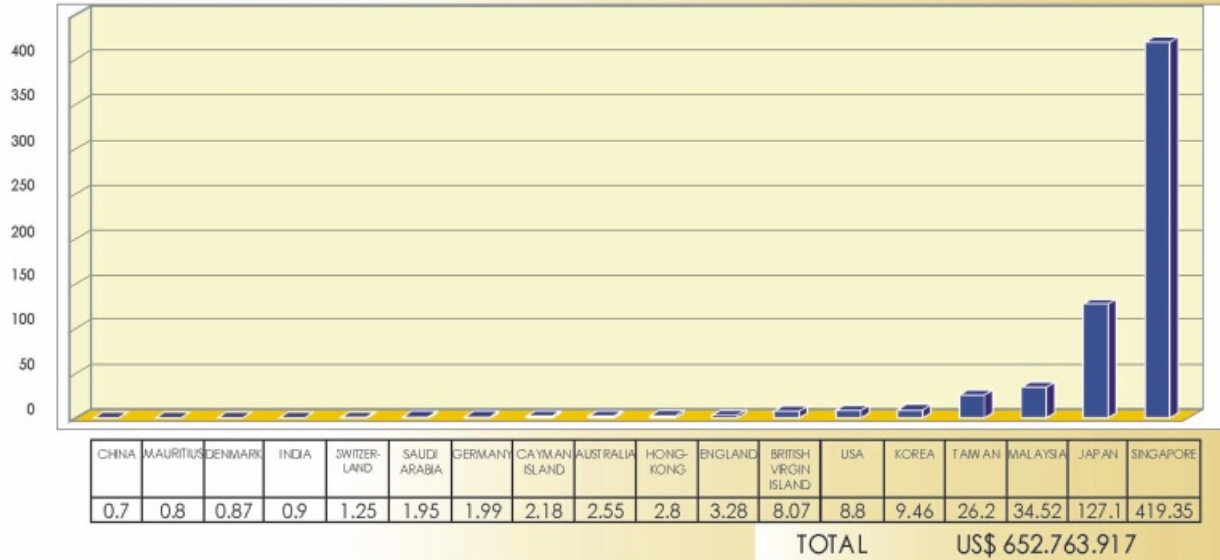

Number of Foreign Companies by Country

Tabel Investasi PMA Berdasarkan Asal Negara

Number of Companies
Jumlah Perusahaan

Up to December 2002
S/d Desember 2002

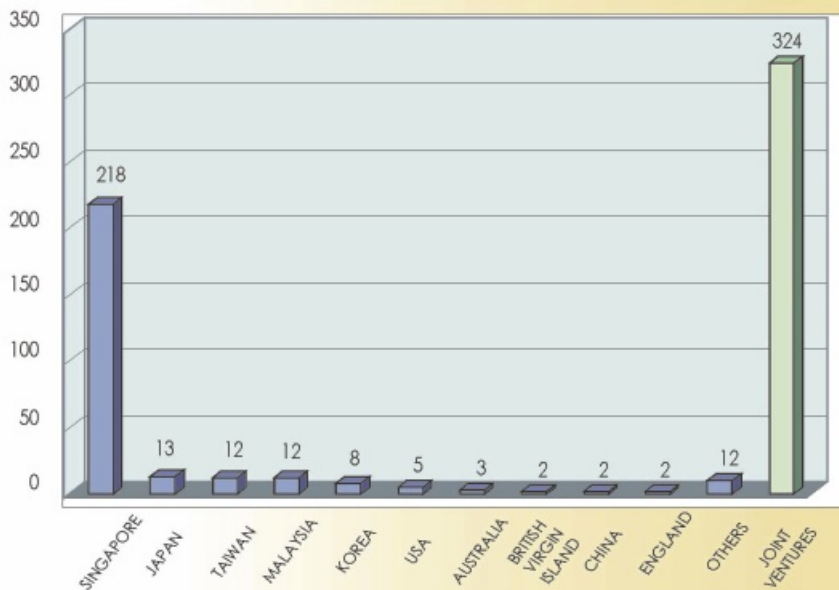

TOTAL 611 Companies / Perusahaan

Indicators of Batam Economic Growth 1998 - 2002

Indikator Pertumbuhan Ekonomi Batam tahun 1998 - 2002

	Remarks	1998	1999	2000	2001	2002
1. INVESTMENT INVESTASI	US \$ Billion US \$ Milyar	6.75	6.98	8.01	8.80	9.46
2. GOVERNMENT INVESTMENT INVESTASI PEMERINTAH	US \$ Billion US \$ Milyar	1.58	1.63	1.90	2.10	2.14
3. FOREIGN INVESTMENT INVESTASI ASING	US \$ Billion US \$ Milyar	2.25	2.33	2.82	3.40	3.62
4. DOMESTIC INVESTMENT INVESTASI DOMESTIK	US \$ Billion US \$ Milyar	2.92	3.02	3.29	3.30	3.70
5. RATIO OF GOVERNMENT TO PRIVATE INVESTMENT RASIO INVESTASI PEMERINTAH DAN SWASTA	Ratio Perbandingan	1 : 3.3	1 : 3.3	1 : 3.2	1 : 3.2	1 : 3.4
6. GROSS DOMESTIC REGIONAL PRODUCT PRODUK DOMESTIK REGIONAL BRUTO	Trillion Rupiah Trilyun Rupiah	5.26	5.9	6.6	8.09	8.53
7. ECONOMIC GROWTH TINGKAT PERTUMBUHAN EKONOMI	Percent Persen	3.08	6.38	7.67	7.90	8.35
8. FOREIGN COMPANIES PERUSAHAAN ASING	Companies Perusahaan	338	396	470	531	611
9. SMALL & MEDIUM ENTERPRISE USAHA KECIL & MENENGAH	Companies Perusahaan	7,809	8,179	9,577	9,700	9,886
10. POPULATION PENDUDUK	People Orang	266,000	358,000	462,000	520,000	533,521
11. INDONESIAN WORK FORCE TENAGA KERJA INDONESIA	People Orang	141,000	150,000	155,000	165,000	172,709
12. FOREIGN WORK FORCE TENAGA KERJA ASING	People Orang	1,300	1,600	1,700	2,116	2,517
13. COMPARISON PERCENTAGE OF WORK FORCE TO POPULATION GROWTH PROSENASE PERBANDINGAN JUMLAH TENAGA KERJA TERHADAP JUMLAH PENDUDUK	Percent Persen	1 : 1.86	1 : 2.36	1 : 2.94	1 : 3.11	1 : 3.04
14. TRANSFERRED FUNDS TO WORKER'S FAMILIES PENGIRIMAN UANG KE KAMPUNG HALAMAN	Billion Rupiah Milyar Rupiah	106	113	118	125	142
15. TAX REVENUE FROM BATAM PENERIMAAN PAJAK DARI BATAM	Billion Rupiah Milyar Rupiah	769	877	900	946	907
16. REGIONAL REVENUE PENDAPATAN ASLI DAERAH	Billion Rupiah Milyar Rupiah	34	47	70	90	105
17. NON OIL AND GAS OIL EXPORT EKSPORT NON MIGAS	US \$ Billion US \$ Milyar	4.70	4.80	6.70	5.70	5.00
18. FOREIGN VISITORS WISATAWAN ASING	Visitors Pengunjung	1,120,000	1,250,000	1,120,000	1,200,000	1,100,000
19. FOREIGN VISITOR REVENUE PENERIMAAN DARI WISATAWAN ASING	US \$ Million US \$ Juta	415	418	413	428	417
20. PAVED ROADS JALAN BERASPAL	Kilometres Kilometer	484	543	1034	1050	1079
21. ELECTRICITY LISTRIK	Mega Watt Juta Watt	232	232	307	358	377
22. FRESH WATER AIR MINUM	Litre / second Liter / detik	850	1,150	1,210	1,710	1,760
23. HOTEL HOTEL	Hotels Hotel	25	28	32	43	47
24. TELEPHONE LINES TELEPON	Line Unit Satuan Sambungan	26,979	33,360	33,848	42,877	52,877

Land Lease (per m²) in Batam

Tarif Tanah*) per m² di Batam

In Rupiah
Dalam Rupiah

LAND CLASSIFICATION PERUNTUKAN	Payment Pembayaran	BATAM ISLAND / PULAU BATAM											REMPANG-GALANG ISLANDS PULAU REMPANG-GALANG		
		BATAM CENTRE		BATU AMPAR			EAST COAST / PANTAI TIMUR					BATAM SURROUNDING ISLANDS PULAU SEVITAR BATAM	REMPANG ISLAND PULAU REMPANG	GALANG/ GALANG BARU ISLANDS PULAU GALANG/ GALANG BARU	REMPANG-GALANG SURROUNDING ISLANDS PULAU SEVITAR REMPANG GALANG
		C O R E	SUBURBS	NAGOYA	SEIPANAS	MUKA BUNING	SEKUPANG	TANJUNG UNCANG/ SAGLUNG	NONGSA	KABL	TANJUNG RIYAU				
COMMERCIAL KOMERSIAL	Full Payment 30 years	70,500	51,750	93,250	51,750	35,750	44,500	35,750	35,750	44,500	35,750	23,500	31,250	28,250	20,500
	Instalment : 12 months	81,075	59,512.5	107,273.5	59,512.5	41,112.5	51,175	41,112.5	41,112.5	51,175	41,112.5	27,025	35,937.5	32,487.5	23,575
	24 months	91,650	67,275	121,225	67,275	46,475	57,850	46,475	46,475	57,850	46,475	30,550	40,625	36,725	26,650
	36 months	102,225	75,037.5	135,212.5	75,037.5	51,837.5	64,525.5	51,837.5	51,837.5	64,525	51,837.5	34,075	45,312.5	40,962.5	29,725
HOUSING PERUMAHAN	Full Payment 30 years	-	46,500	51,000	42,000	35,500	42,000	35,500	29,000	29,000	29,000	19,250	25,250	22,750	16,750
	Instalment : 12 months	-	53,475	58,650	48,300	40,825	48,300	40,825	33,350	33,350	33,350	22,137.5	29,037.5	26,162.5	19,162.5
	24 months	-	60,450	66,300	54,600	46,150	54,600	46,150	37,700	37,700	37,700	25,025	32,825	29,575	21,775
	36 months	-	67,425	73,950	60,900	51,475	60,900	51,475	42,050	42,050	42,050	27,912.5	36,612.5	32,987.5	24,287.5
TOURISM PARIWISATA	Full Payment 30 years	51,250	36,250	36,250	36,250	25,000	30,500	30,500	36,250	30,500	25,000	16,000	21,750	19,500	14,000
	Instalment : 12 months	58,937.5	41,687.5	41,687.5	41,687.5	28,750	35,075	35,075	41,687.5	35,075	28,750	18,400	25,012.5	22,245	16,100
	24 months	66,625	47,125	47,125	47,125	32,500	39,650	39,650	47,125	39,650	32,500	20,800	28,275	25,350	18,200
	36 months	74,312.5	52,562.5	52,562.5	52,562.5	36,250	44,225	44,225	52,562.5	44,225	36,250	23,200	31,537	28,275	20,300
INDUSTRIAL INDUSTRI	Full Payment 30 years	-	32,250	-	49,500	22,500	22,500	22,500	32,250	32,250	22,500	14,500	19,500	17,750	12,750
	Instalment : 12 months	-	37,087.5	-	56,925	25,875	25,875	25,875	37,087.5	37,087.5	25,875	16,675	22,245	20,412.5	14,662.5
	24 months	-	41,925	-	64,350	29,250	29,250	29,250	41,925	41,925	29,250	18,850	25,350	23,075	16,575
	36 months	-	46,762.5	-	71,775	32,625	32,625	32,625	46,762.5	46,762.5	32,625	23,200	28,275	25,737.5	18,487.5
AGRICULTURE PERTANIAN	Full Payment 30 years	-	-	-	-	16,000	18,500	18,500	-	-	18,500	8,000	14,000	12,750	7,000
	Instalment : 12 months	-	-	-	-	18,400	21,275	21,275	-	-	21,275	9,200	16,100	14,662.5	8,050
	24 months	-	-	-	-	20,800	24,050	24,050	-	-	24,050	10,400	18,200	16,575	9,100
	36 months	-	-	-	-	23,200	26,825	26,825	-	-	26,825	11,600	20,300	18,487.5	10,150
FISHERIES PERIKANAN	Full Payment 30 years	-	-	-	-	10,750	9,500	9,500	-	-	10,750	4,500	8,250	7,500	3,750
	Instalment : 12 months	-	-	-	-	12,362.5	10,925	10,925	-	-	12,362.5	5,175	9,487.5	8,625	4,312.5
	24 months	-	-	-	-	13,975	12,350	12,350	-	-	13,975	5,850	10,725	9,750	4,875
	36 months	-	-	-	-	15,587.5	13,775	13,775	-	-	15,587.5	6,525	11,962.5	10,875	5,437.5
GOVERNMENT OFFICE AND BUILDING BANGUNAN DAN KANTOR PEMERINTAHAN	Full Payment 30 years	14,250	6,750	6,000	6,000	5,250	6,000	5,250	5,250	5,250	5,250	2,500	4,500	4,250	2,000
	Instalment : 12 months	16,387.5	7,762.5	6,900	6,900	6,037.5	6,900	6,037.5	6,037.5	6,037.5	6,037.5	2,875	5,175	4,887.5	2,300
	24 months	18,525	8,775	7,800	7,800	6,8250	7,800	6,8250	6,8250	6,8250	6,8250	3,250	5,850	5,525	2,600
	36 months	20,662.5	9,787	8,870	8,870	7,612.5	8,870	7,612.5	7,612.5	7,612.5	7,612.5	3,625	6,525	6,162.5	2,900
RELIGIOUS, SOCIAL & EDUCATION FACILITIES BANGUNAN FAS. IBADAH, SOSIAL DAN PENDIDIKAN	Full Payment 30 years	11,250	5,000	4,500	4,000	4,500	4,000	4,000	4,000	4,000	4,000	1,000	3,500	3,000	1,000
	Instalment : 12 months	12,937.5	5,750	5,175	4,600	5,175	4,600	4,600	4,600	4,600	4,600	1,150	4,025	3,450	1,150
	24 months	14,625	6,500	5,850	5,200	5,850	5,200	5,200	5,200	5,200	5,200	1,300	4,550	3,900	1,300
	36 months	16,312.5	7,250	6,525	5,800	6,525	5,800	5,800	5,800	5,800	5,800	1,450	5,075	4,350	1,450
SPORTING FACILITIES/ GOLF COURSES LAPANGAN GOLF DAN FASILITAS OLAH RAGA	Full Payment 30 years	-	-	18,500	18,500	18,500	18,500	-	18,500	-	-	-	16,000	14,500	-
	Instalment : 12 months	-	-	21,275	21,275	21,275	21,275	-	21,275	-	-	-	18,400	16,675	-
	24 months	-	-	24,050	24,050	24,050	24,050	-	24,050	-	-	-	20,800	18,850	-
	36 months	-	-	26,825	26,825	26,825	26,825	-	26,825	-	-	-	23,200	23,200	-
READY - TO - BUILD LOT KAWLING SIAP BANGUN	Full Payment 30 years	-	6,000	6,000	6,000	6,000	6,000	6,000	6,000	6,000	6,000	6,000	6,000	6,000	6,000
	Instalment : 12 months	-	6,900	6,900	6,900	6,900	6,900	6,900	6,900	6,900	6,900	6,900	6,900	6,900	6,900
	24 months	-	7,800	7,800	7,800	7,800	7,800	7,800	7,800	7,800	7,800	7,800	7,800	7,800	7,800
	36 months	-	8,700	8,700	8,700	8,700	8,700	8,700	8,700	8,700	8,700	8,700	8,700	8,700	8,700
LOW COST HOUSING RUMAH SANGAT SEDERHANA	Full Payment 30 years	-	18,000	18,000	18,000	18,000	18,000	18,000	18,000	18,000	18,000	18,000	18,000	18,000	18,000
	Instalment : 12 months	-	20,700	20,700	20,700	20,700	20,700	20,700	20,700	20,700	20,700	20,700	20,700	20,700	20,700
	24 months	-	23,400	23,400	23,400	23,400	23,400	23,400	23,400	23,400	23,400	23,400	23,400	23,400	23,400
	36 months	-	26,100	26,100	26,100	26,100	26,100	26,100	26,100	26,100	26,100	26,100	26,100	26,100	26,100
LOW COST APARTMENT RUMAH SUSUN	Full Payment 30 years	-	6,000	6,000	6,000	6,000	6,000	6,000	6,000	6,000	6,000	6,000	6,000	6,000	6,000
	Instalment : 12 months	-	6,900	6,900	6,900	6,900	6,900	6,900	6,900	6,900	6,900	6,900	6,900	6,900	6,900
	24 months	-	7,800	7,800	7,800	7,800	7,800	7,800	7,800	7,800	7,800	7,800	7,800	7,800	7,800
	36 months	-	8,700	8,700	8,700	8,700	8,700	8,700	8,700	8,700	8,700	8,700	8,700	8,700	8,700

*) Uang Wajib Tahunan Otorita (UWTO)

List of Hotels, Golf Courses and Marina

Daftar Hotel, Lapangan Golf dan Marina

No	Hotel & Resort	Rating	Address	Phone (62-778)	Fax (62-778)
01	Batam View Beach Resort	★★★★	Jl. Hang Lekir Nongsa	761740/1	761747
02	Harmoni	★★★★	Jl. Imam Bonjol Blok B No 1	459308	459306
03	Holiday Inn	★★★★	Water Front City	381333	381332
04	Hotel Goodway	★★★★	Jl. Imam Bonjol No 1	426888	458057
05	Melia Panorama	★★★★	Panorama Komp. Nagaya	452888	452555
06	Nongsa Point Marina	★★★★	Jl Hang Lekieu Nongsa	761333	761474
07	Novotel	★★★★	Jl. Duyung Sei Jodoh	425555	427502
08	Pura Jaya Beach Resort	★★★★	Jl. Hang Lekieu Nongsa	761345	761438
09	Turi Beach Resort	★★★★	Jl Teluk Mata Ikan Nongsa	761080	761042/3
10	Harris Resort	★★★	Marina Water Front City	381888	381142
11	Island Garden	★★★	Komp. Villa Idaman Baloi	457500	457300
12	Island View	★★★	Jl. Prambanan No.1	430500	431500
13	Nagoya Plaza	★★★	Jl. Imam Bonjol Nagoya	459888	456690
14	Puri Garden	★★★	Jl. Teuku Umar No.1 Nagoya	458888	456333
15	Royal Eastern	★★★	Jl. Raden Patah No.12	452777	453474
16	Sahid Rashinta	★★★	Komp. Rashinta Nagoya	455888	452231
17	Seruni	★★★	Jl. Seraya Komp. Nagoya	456333	426750
18	Vista	★★★	Komp. Top View Garden	431888	431877
19	Formosa	★★	Komp. City Plaza Blok A No.8	426789	426722
20	Gita Wisata	★★	Jl. Gunung Bromo, Baloi	458105/6	457762
21	Hill Top	★★	Jl. Ir. Sutami No.8 Sekupang	422482	322211
22	Oasis	★★	Jl. Duyung Sei Jodoh	427711	427712
23	Sari Jaya	★★	Komp. Bumi Indah Nagoya	451338	451342
24	Singa	★★	Jl. Sriwijaya No.18, Pelita	451919	457471
25	Bumi Nusantara	★	Jl. Gunung Bromo No.79	424444	457727
26	Holiday	★	Jl. Imam Bonjol B/1, Nagoya	458616	457531
27	Horisona	★	Jl. Sultan Abd. Rahman Blok E No.1-7	457111	457123
28	Hotel 88	★	Jl. Raden Patah, Baloi Blok 3	424988	452722
29	Ozon	★	Komp Penuin Centre Blok H No.1	428888	428785
30	Kolekta	★	Jl. Raden Patah No.12	451333	421404
31	Merlin	★	Jl. Sriwijaya Komp. Regency Park	427900	452934
32	Pelangi	★	Komp Tg. Pantun Blok J5 Sei Jodoh	451555	455122
33	Pelita	★	Jl. Sriwijaya No.23	450620	425988
34	Ramayana	★	Jl. Pembangunan II	456888	457764
35	Sentosa	★	Raja Ali Haji Jodoh	452345	452330

No	Golf Course & Marina	Address	Phone (62-778)	Fax (62-778)
01	Tering Bay Golf & Country Club	Nongsa	761818	761908
02	Palm Spring Golf & Beach Resort	Nongsa	761222	761228
03	Indah Puri Golf & Resort	Sekupang	323702	310418
04	Paradise Bay Golf & Resort	Tanjung Uncang	321063	321894
05	Southlinks Golf & Country Club	Sekupang	424128	323313
06	Tering Bay Golf & Coutry Club	Nongsa	761027	761250
07	Nongsa Point Marina	Nongsa	761333	761474
08	Marina Waterfront City	Tanjung Uncang	381067	381059



Head Office, Batam



Representative Office, Jakarta

Batam Industrial Development Authority

Office:

Batam Centre, Batam 29400, Indonesia, Phone: (62-778) 462047, 462048, Fax: (62-778) 462240, 462456

Representative Office:

Jl. D.I. Panjaitan, Kav. 24, Jakarta 13410, Phone: (62-21) 8580009-11, Fax: (62-21) 8580038

Website: www.batam.go.id

E-mail: inquiry@batam.go.id